



Department of Computing and Information System

Md. Selim Hossain, Senior Lecturer, CIS, DIU

1

Md. Selim Hossain, Senior Lecturer, CIS, DIU

Sequential And Combinational ALU

Topics to be covered

- Introduction to ALU
- Introduction to Combinational Circuits
- Design Procedure of Combinational Circuits
- Analysis Procedure of Combinational Circuits
- Introduction to Sequential Circuits
- Types of Sequential Circuits

Introduction to ALU

- ALU stands for: **A**rithmetic **L**ogic **U**nit
- ALU is a digital circuit that performs Arithmetic (Add, Sub, . . .) and Logical (AND, OR, NOT) operations.
- John Von Neumann proposed the ALU in 1945 when he was working on EDVAC.

Introduction to ALU (contd...)

- An ALU is the fundamental unit of any computing system.
- Understanding how an ALU is designed and how it works is essential to building any advanced logic circuits.
- Using this knowledge and experience, we can move on to designing more complex integrated circuits.
- The ALU is the “heart” of a processor—you could say that everything else in the CPU is there to support the ALU.

Typical Schematic Symbol of an ALU

A and B: the inputs to the ALU
(aka operands)

R: Output or Result

F: Code or Instruction from the
Control Unit

D: Output status; it indicates
cases such as:

- carry-in
- carry-out,
- overflow,
- division-by-zero
- And . . .

TYPES OF DIGITAL LOGIC CIRCUITS IN ALU

- COMBINATIONAL CIRCUITS
- SEQUENTIAL CIRCUITS

INTRODUCTION TO COMBINATIONAL CIRCUITS

- Combinational Circuits are made of logic gates.
- Doesn't contain memory element, that's why they can't store any information.
- Value of present output is determined by present input.
- Examples of combinational circuits are half adders, full adders, subtractors etc.

BLOCK DIAGRAM OF A COMBINATIONAL CIRCUIT



Combinational Circuits Based ALU

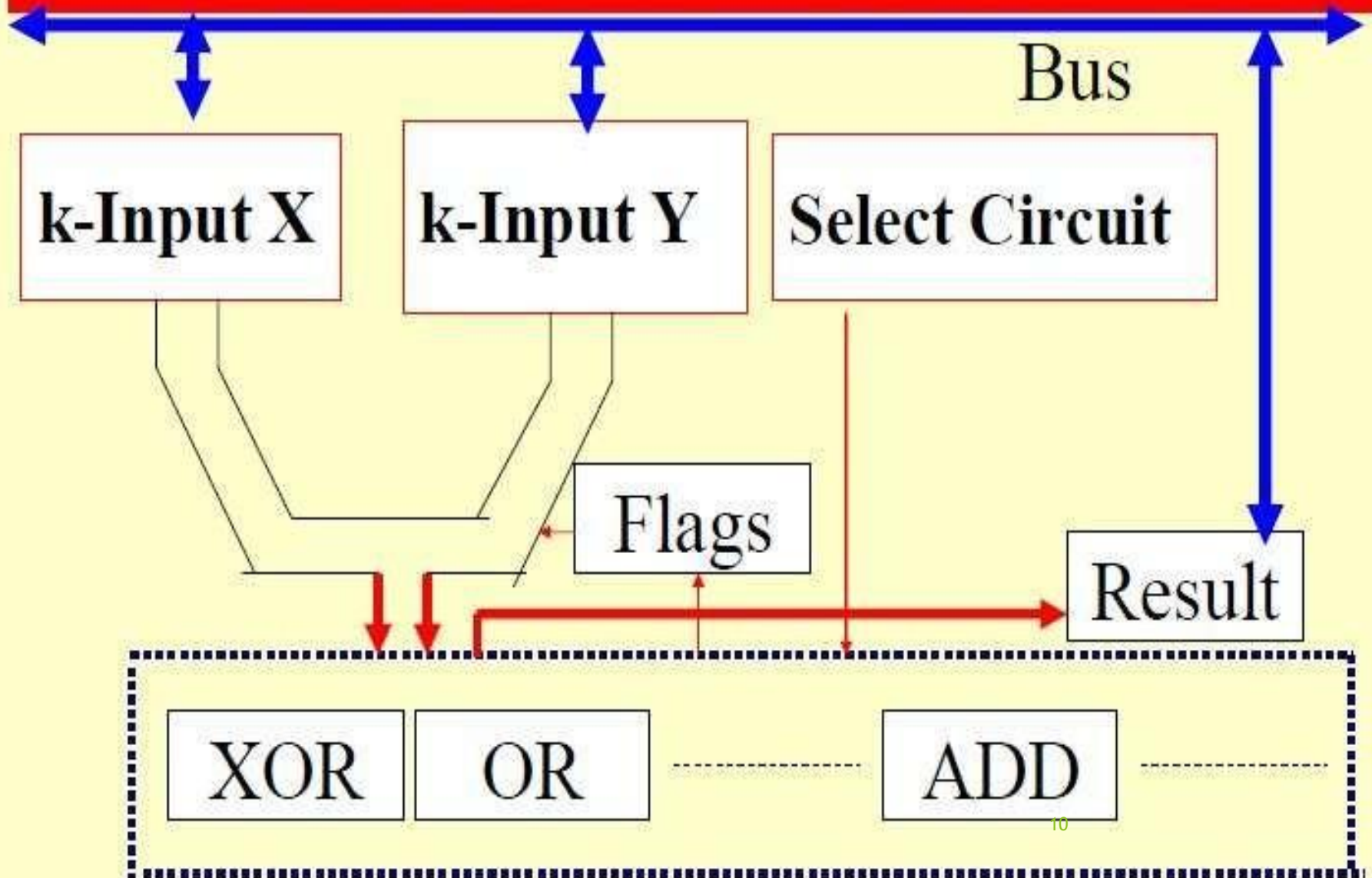

Examples of Combinational Circuits:

- Multiplexer
- Demultiplexer
- Encoder
- Decoder
- Half Adder
- Full Adder

Multiplexer & Demultiplexer

○ Multiplexer-

- A multiplexer is a combinational circuit where binary information from one of many input lines is selected and directs it to a single output line.

○ Demultiplexer-

- Demultiplexing is the reverse process of multiplexing; i.e., a demultiplexer is a combinational circuit that receives information on a single line and transmits this information on one of 2^n possible output lines.

Encoder & Decoder

○ Encoder-

- An encoder is a combinational circuit that produces the reverse function from that of a decoder.

○ Decoder-

- A decoder is a combinational logic circuit that receives coded information on n input lines and feeds them to maximum of 2^n unique output lines after conversion.

Half-Adder & Full-Adder

○ Half-Adder :

- A half-adder is a combinational circuit that performs the addition of two bits.

○ Full Adder :

- This type of adder is a little more difficult to implement than a half-adder.
- The main difference between a half-adder and a full-adder is that the full-adder has three inputs and two outputs.

DESIGN PROCEDURE OF COMBINATIONAL CIRCUITS

This procedure involves the following steps:

- The problem is stated.
- The number of available input variables and output variables is determined.
- The input and output variables are assigned letter symbols.
- Truth table is drawn
- Boolean function for output is obtained.
- The logic diagram is drawn.

ANALYSIS PROCEDURE OF COMBINATIONAL CIRCUIT

- TO DETERMINE THE OUTPUT FUNCTIONS AS ALGEBRAIC EXPRESSIONS.
- It is the reverse process of design procedure.
- Logic diagram of the circuit is given.
- Obtain the truth table from the diagram.
- Obtain Boolean function from the Truth Table for output.

SEQUENTIAL LOGIC CIRCUITS

- Made up of **combinational circuits and memory elements.**
- These memory elements are devices capable of storing **ONE-BIT information.**
- **Output depends on input and previous state.**
- Examples of sequential circuits are **flip flops, counters, shift registers**

BLOCK DIAGRAM OF A SEQUENTIAL CIRCUIT

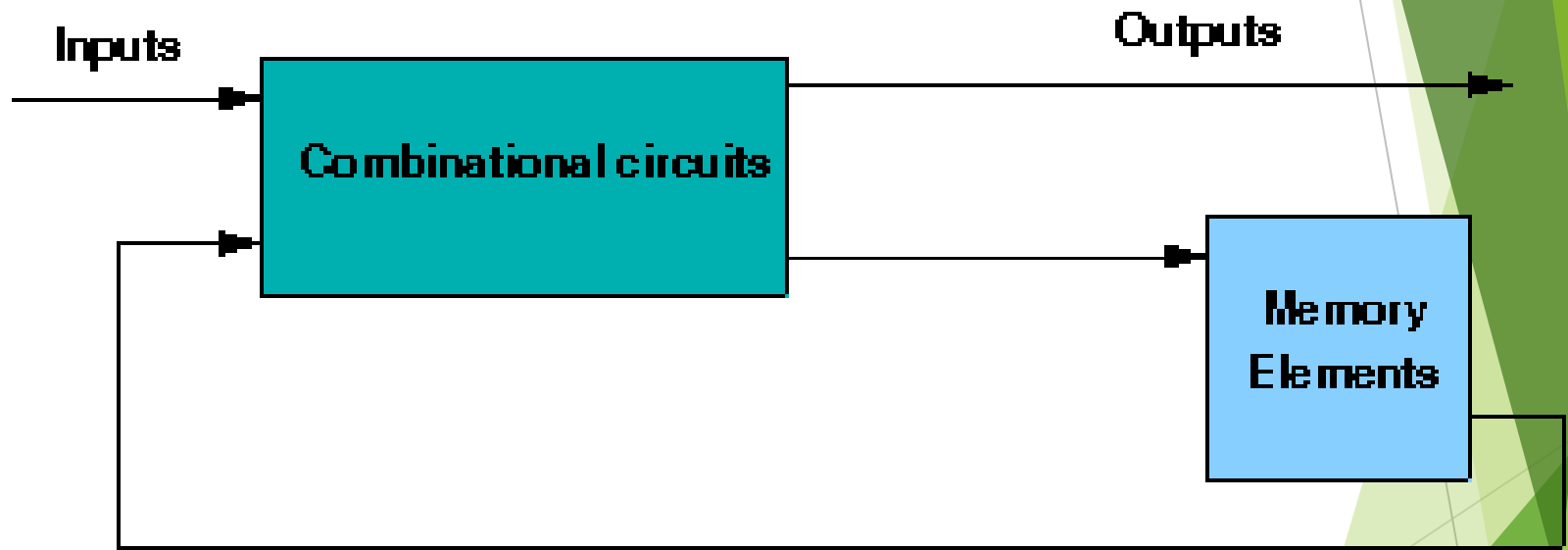

Sequential Logic Circuits Based ALU

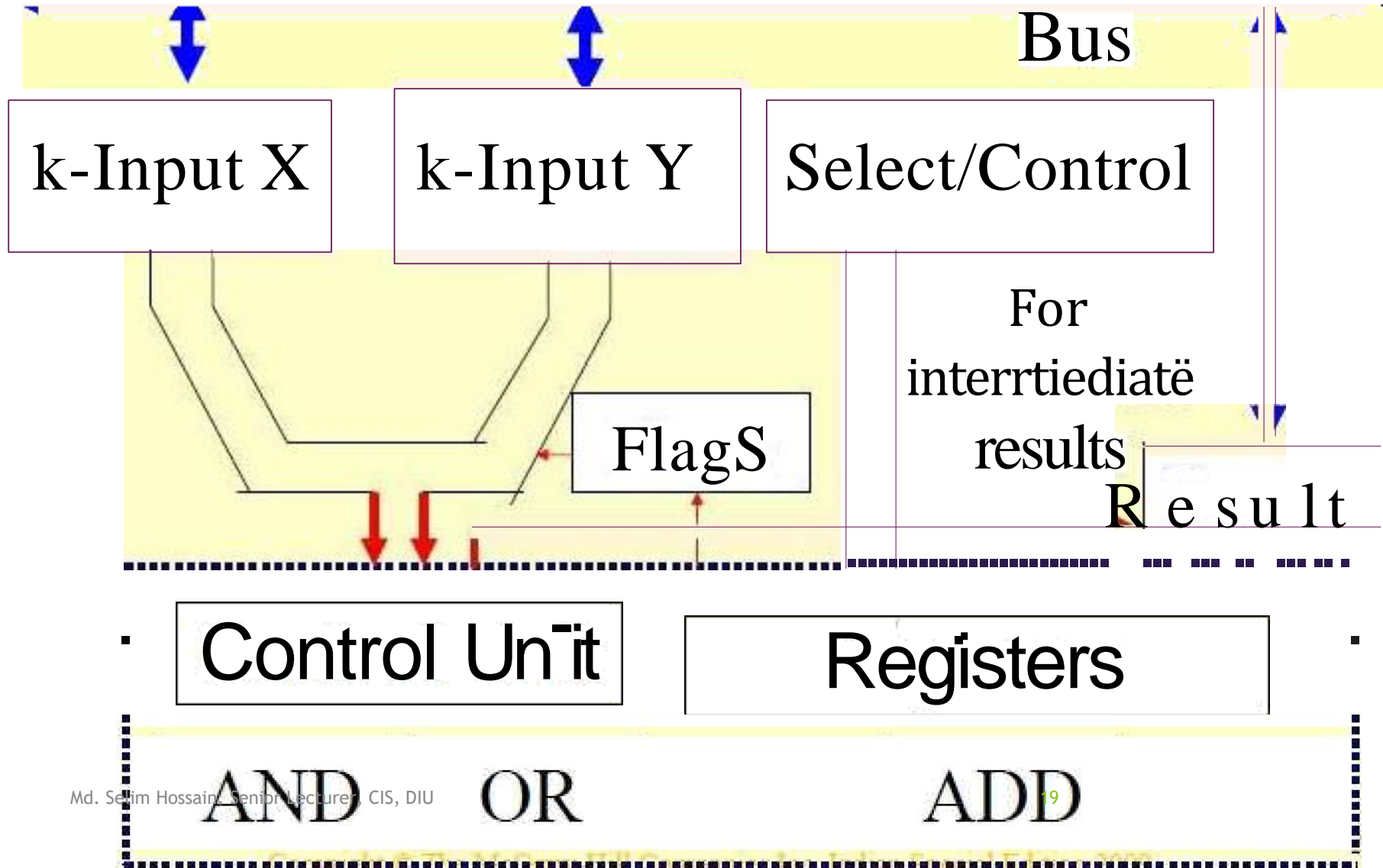

Examples of Sequential Circuits :

○ Flip-Flops

- JK Flip-Flop
- RS Flip-Flop
- T Flip-Flop
- D Flip-Flop

○ Registers

○ Counters

Flip-Flops

- Flip-Flops are the basic building blocks of sequential circuits.
- A flip-flop is a binary cell which can store a bit of information.
- A basic function of flip-flop is storage, which means memory. A flip-flop (FF) is capable of storing 1 (one) bit of binary data.
- It has two stable states either '1' or '0'. A flip-flop maintains any one of the two stable states which can be treated as zero or one depending on presence and absence of output signals.

Registers and Counters

- A circuit with flip-flops is considered a sequential circuit even in the absence of combinational logic.
- Circuits that include flip-flops are usually classified by the function they perform.
- Two such circuits are registers and counters:
- **Registers-**
 - It is a group of flip-flops.
 - Its basic function is to hold information within a digital system so as to make it available to the logic units during the computing process.
- **Counters-**
 - It is essentially a register that goes through a predetermined sequence of states.

TYPES OF SEQUENTIAL CIRCUITS

Sequential circuits are of two types:

- *SYNCHRONOUS SEQUENTIAL CIRCUITS*
- *ASYNCHRONOUS SEQUENTIAL CIRCUITS*

→ SYNCHRONOUS CIRCUITS

- In synchronous sequential circuits, the state of the device changes only at discrete times in response to a clock Pulse.
- In a synchronous circuit, an electronic oscillator called a *clock* generates a sequence of repetitive pulses called the *clock signal* which is distributed to all the memory elements in the circuit.

→ ASYNCHRONOUS CIRCUITS

- Asynchronous circuit is not synchronized by a clock signal; the outputs of the circuit change directly in response to changes in Inputs.
- The advantage of asynchronous logic is that it can be faster than synchronous logic, because the circuit doesn't have to wait for a clock signal to process inputs.
- The speed of the device is potentially limited only by the propagation delays of the logic gates used.

Half Adder Circuit

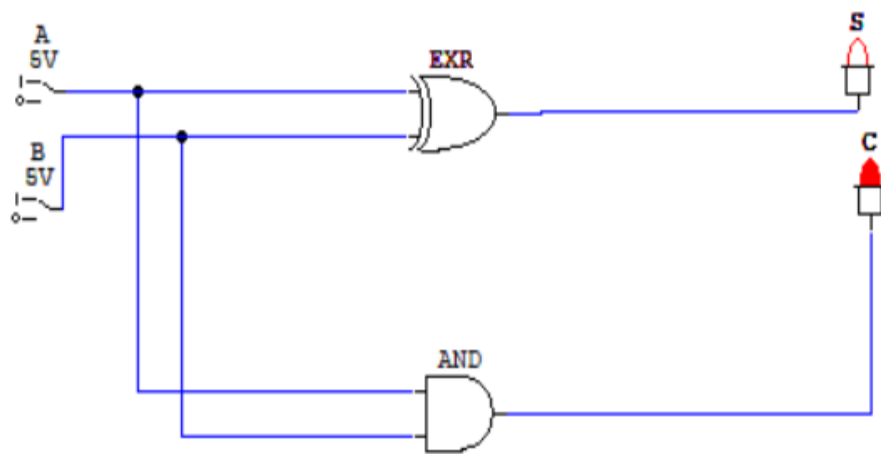

Thanks to All