

Software Project Management Project Scheduling

✓ CPM

✓ Gantt chart



Project Work Plan (/Scheduling)

- It is a dynamic document that defines the list of tasks and important information about each task.
- A project plan includes: start date, completion date, estimated duration, actual duration, precedence information, deliverables, completion status, required resources, key milestones, staffing plan, etc.
- Common Tools to produce a Workplan
 - Gantt Chart - is a type of bar chart that illustrates a project schedule.

LECTURE – CPM

- **Project Scheduling**
- **Project Scheduling Objectives**
- **Phases of Project Scheduling**
- **CPM – Critical Path Method**

PROJECT

SCHEDULING

- It is part of project management within the **Planning** phase of the Systems Development Life Cycle.
- **Project Scheduling: Allocate resources to execute all activities in the project.**



SCHEDULE



- **Project:** Set of activities or tasks with a clear *beginning* and *ending* points. The amount of available resources (time, personnel and budget) to carry out the activities is usually limited.

PROJECT

SCHEDULING

Objectives:

- Establish **beginning, ending and duration** of each activity in the project.
- Calculate overall completion time of the project given the amount of usually limited resources.
- Determine the **critical path** and its **duration**.
- Determine the **slack time** for all **non-critical activities** and the whole project.
- Guide the allocation of resources other than time such as staff and budget.

PROJECT

SCHEDULING

Phase:

- S: Define activities or tasks according to the project objectives.
 - A task is an individual unit of work with a clear beginning and a clear end.
 - Identify precedence relationships or dependencies
 - Estimate time required to complete each task.
 - Draw an activity-on-arrow PERT diagram inserting dummy activities if required.
 - Apply CPM to calculate *earliest and latest starting times, earliest and latest completion times, slack times, critical path* etc.
 - Construct a GANTT chart.
 - Reallocate resources and resolve if necessary.
 - Continuously monitor/revise the time estimates along the project duration.

CPM – CRITICAL PATH

METHOD

- It is determined by adding the times for the activities in each sequence.
- CPM determines the total calendar time required for the project.
- If activities outside the critical path speed up or slow down (within limits), the total project time does not change.
- The amount of time that a non-critical activity can be delayed without delaying the project is called slack-time.

CPM – CRITICAL PATH

METHOD

- **ET** – Earliest node time for given activity duration and precedence relationships
- **LT** – Latest node time assuming no delays

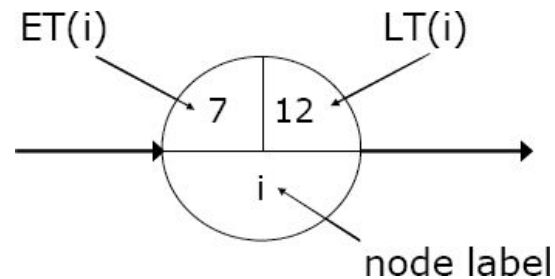

- **ES** – Activity earliest start time
- **LS** – Activity latest start time
- **EF** – Activity earliest finishing time
- **LF** – Activity latest finishing time
- **Slack Time** – Maximum activity delay time

CPM – CRITICAL PATH

METHOD

Step 1. Calculate ET for each node.

For each node i for which predecessors j are labelled with $ET(j)$, $ET(i)$ is given

by:

$$ET(i) = \max_j [ET(j) + t(j,i)]$$

where $t(j,i)$ is the duration of task between nodes

(j,i) . Step 2. Calculate LT for each node.

For each node i for which successors j are labelled with $LT(j)$, $LT(i)$ is given

by:

where $t(j,i)$ is the duration of task between nodes (i,j) .

$$LT(i) = \min_j [LT(j) - t(i,j)]$$

CPM – CRITICAL PATH

METHOD

Step 3. Calculate processing times for each activity. For each activity X with start node i and end node j:

$$ES(X) = ET(i)$$

$$EF(X) = ES(X) + t(X)$$

$$LF(X) = LT(j)$$

$$LS(X) = LF(X) - t(X)$$

$$\text{Slack Time (X)} = LS(X) - ES(X) = LF(X) - EF(X)$$

Where $t(X)$ is the duration of activity X.

An activity with **zero slack time** is a **critical activity** and cannot be delayed without causing a delay in the whole project.

CPM – CRITICAL PATH METHOD

Task	Precedence	Duration
A	-	3
B	-	4
C	B	7
D	A	5
E	C	2

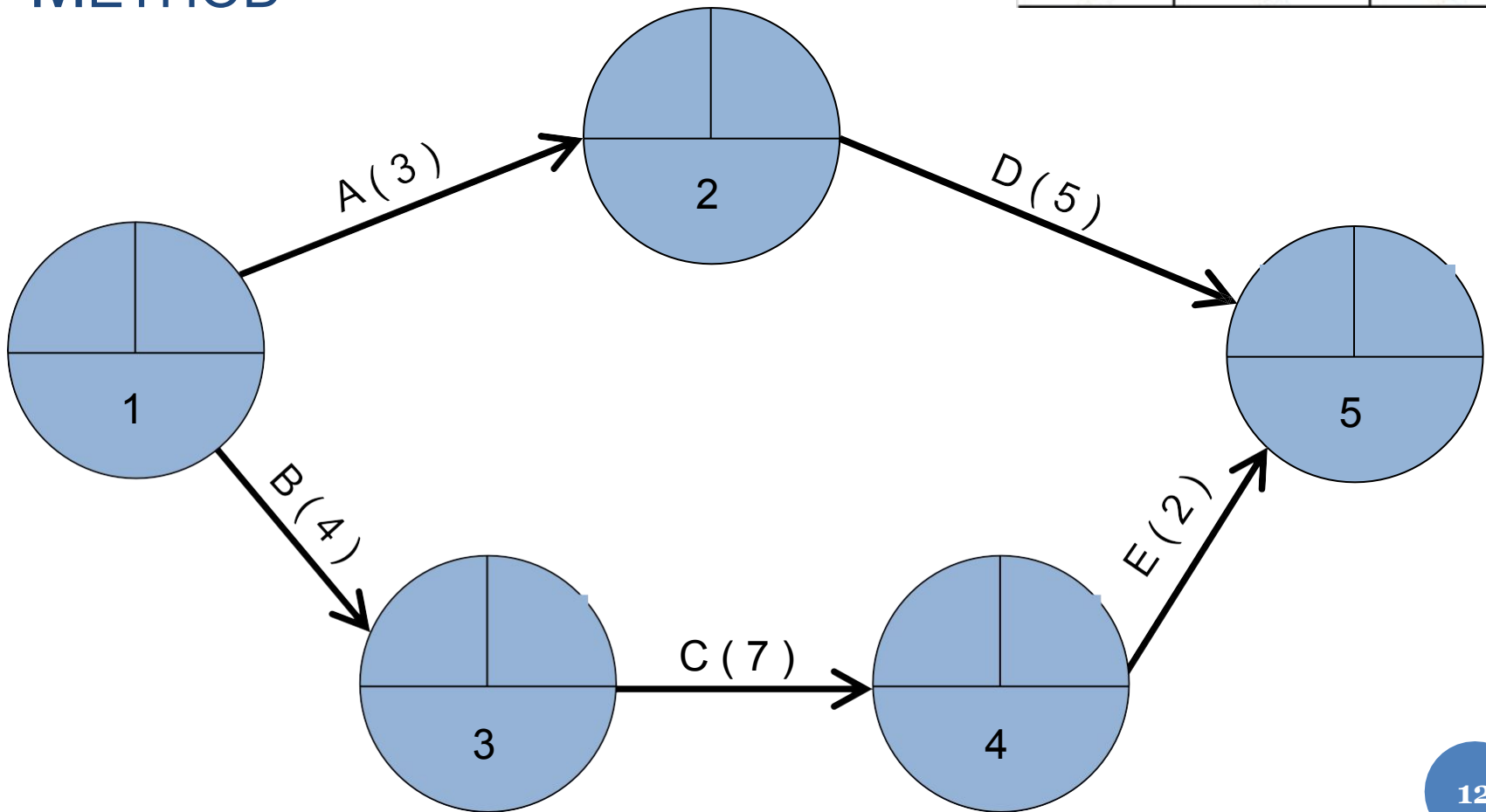

CPM – CRITICAL PATH METHOD

Task	Precedence	Duration
A	-	3
B	-	4
C	B	7
D	A	5
E	C	2

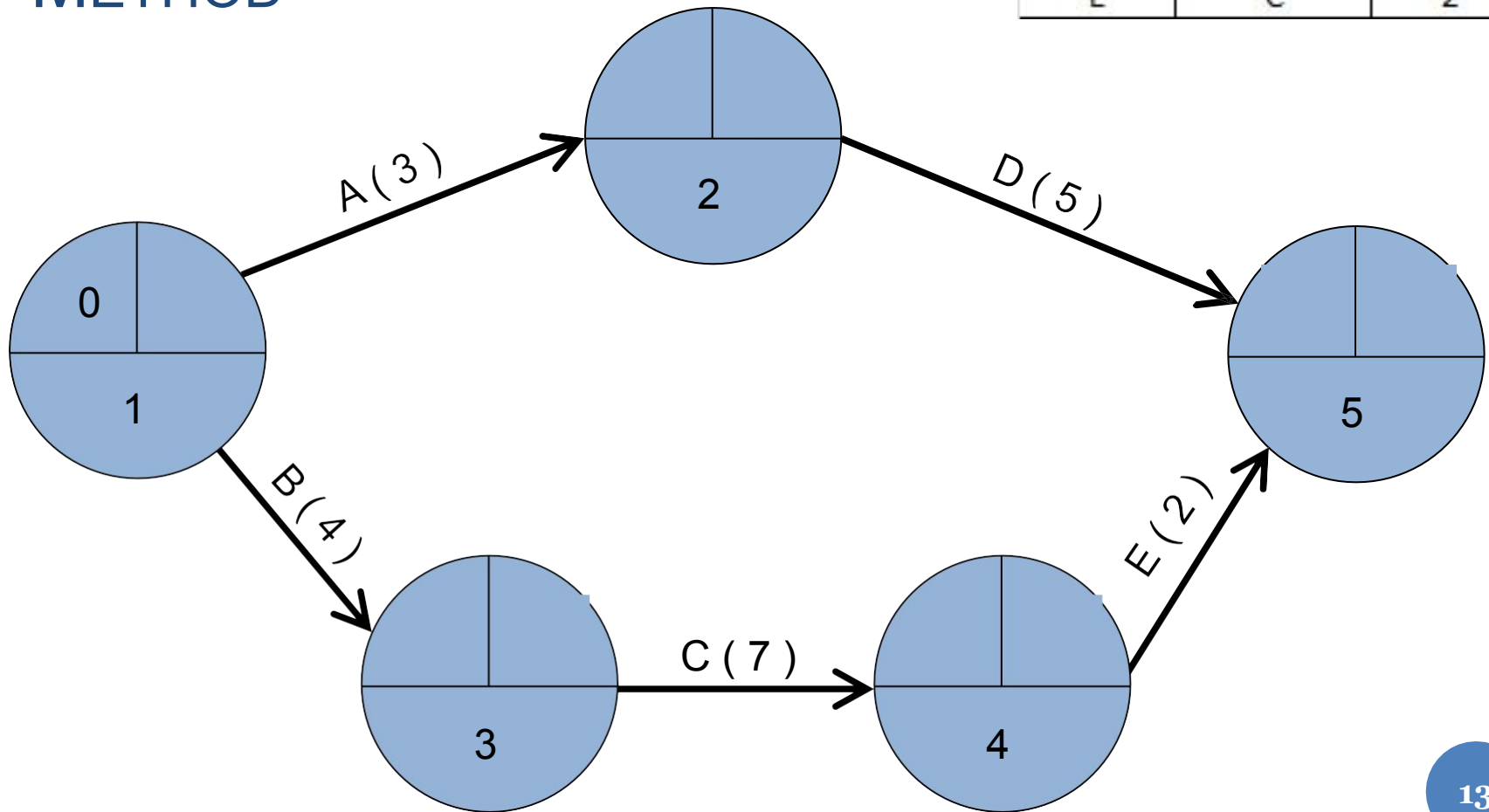

CPM – CRITICAL PATH METHOD

Task	Precedence	Duration
A	-	3
B	-	4
C	B	7
D	A	5
E	C	2

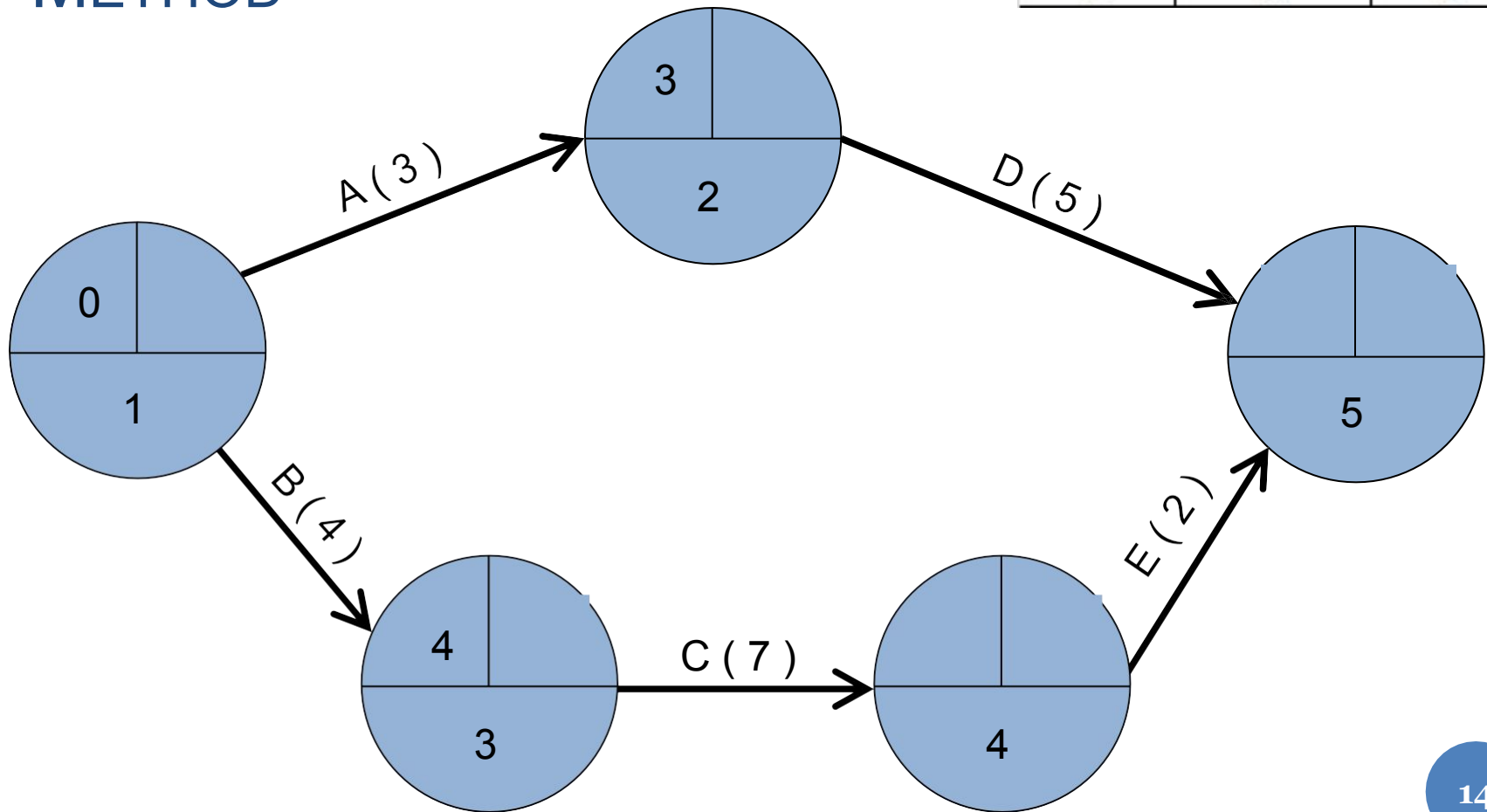

CPM – CRITICAL PATH METHOD

Task	Precedence	Duration
A	-	3
B	-	4
C	B	7
D	A	5
E	C	2

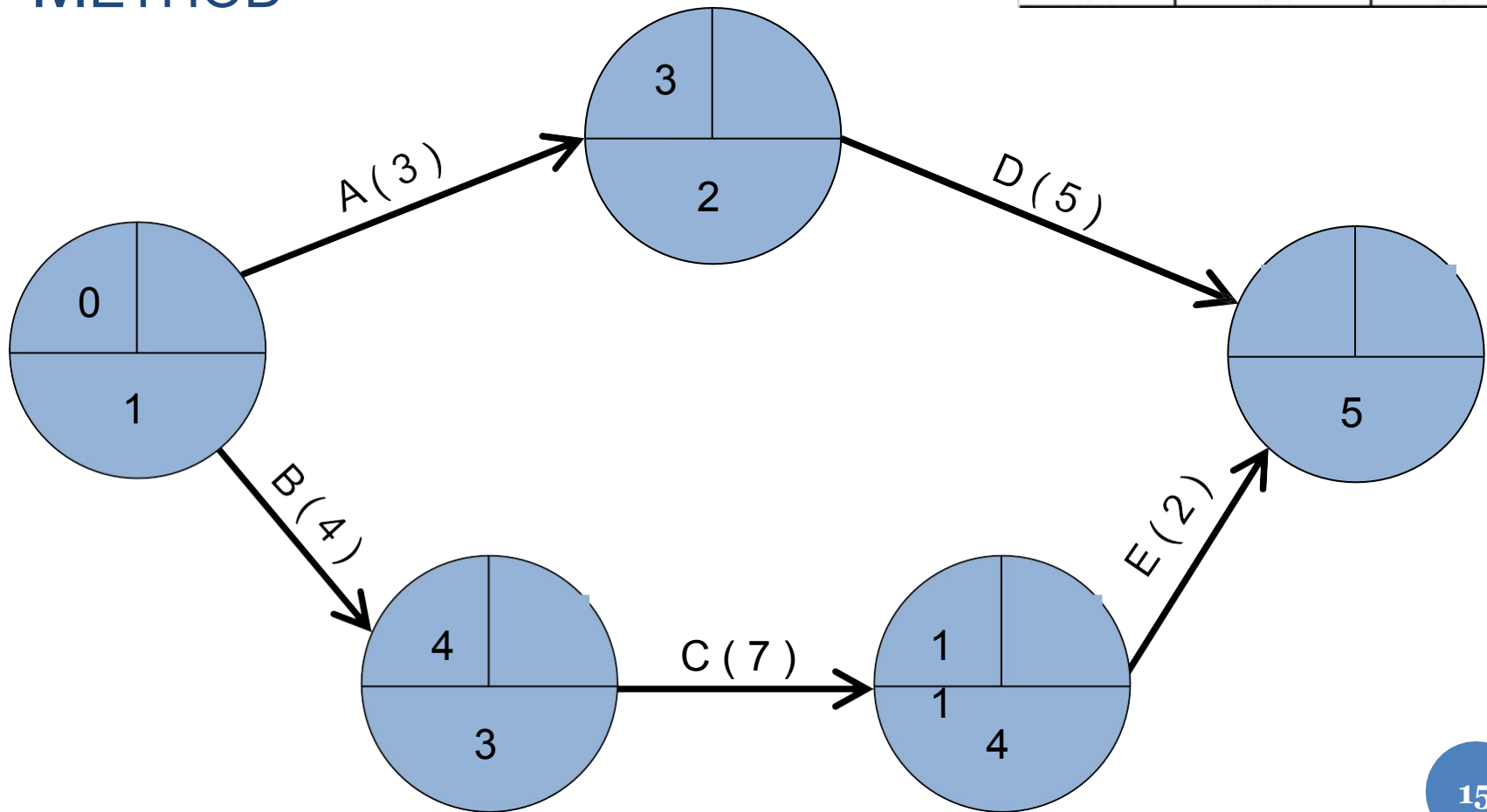

CPM – CRITICAL PATH METHOD

Task	Precedence	Duration
A	-	3
B	-	4
C	B	7
D	A	5
E	C	2

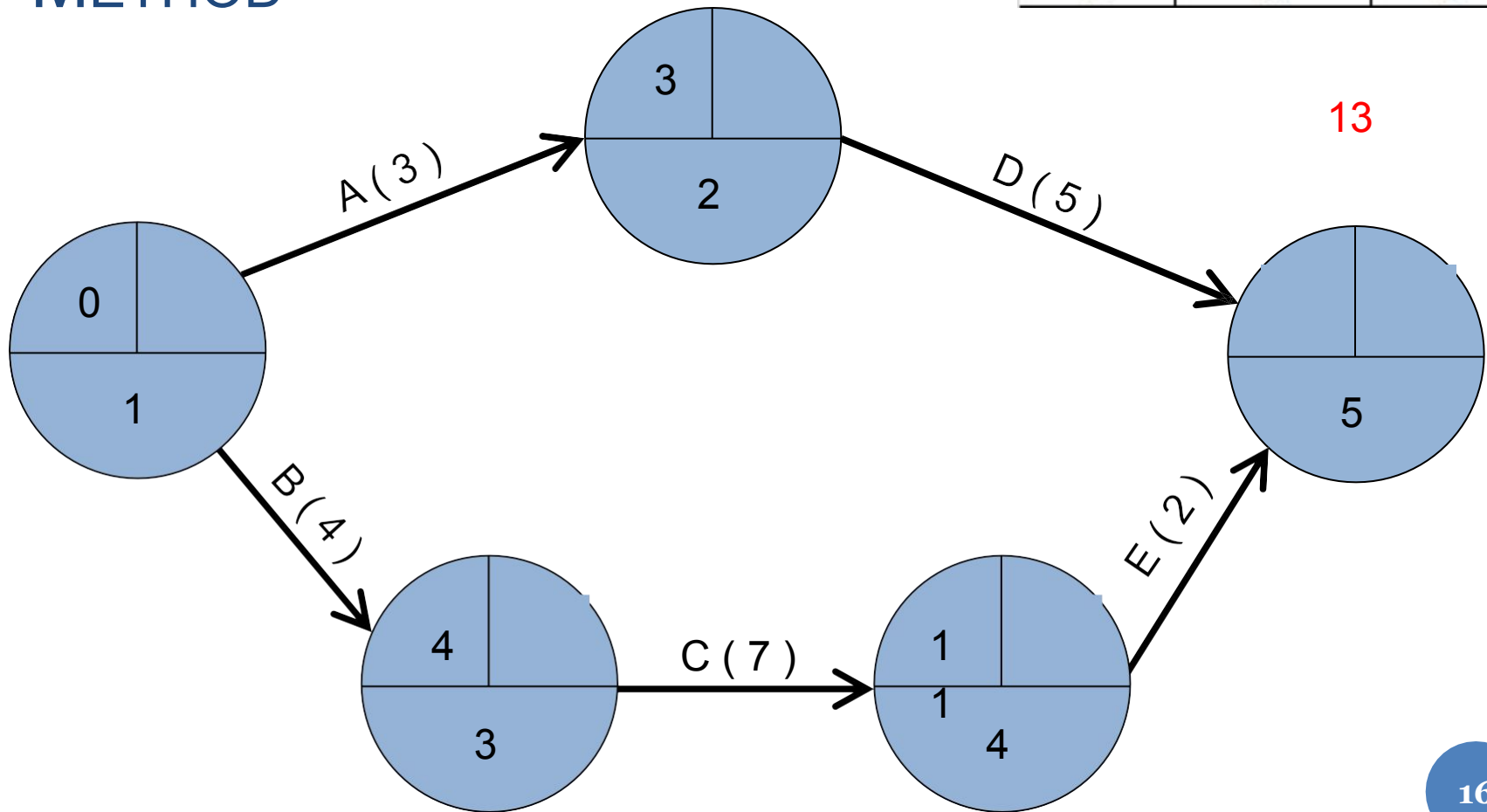

CPM – CRITICAL PATH METHOD

Task	Precedence	Duration
A	-	3
B	-	4
C	B	7
D	A	5
E	C	2

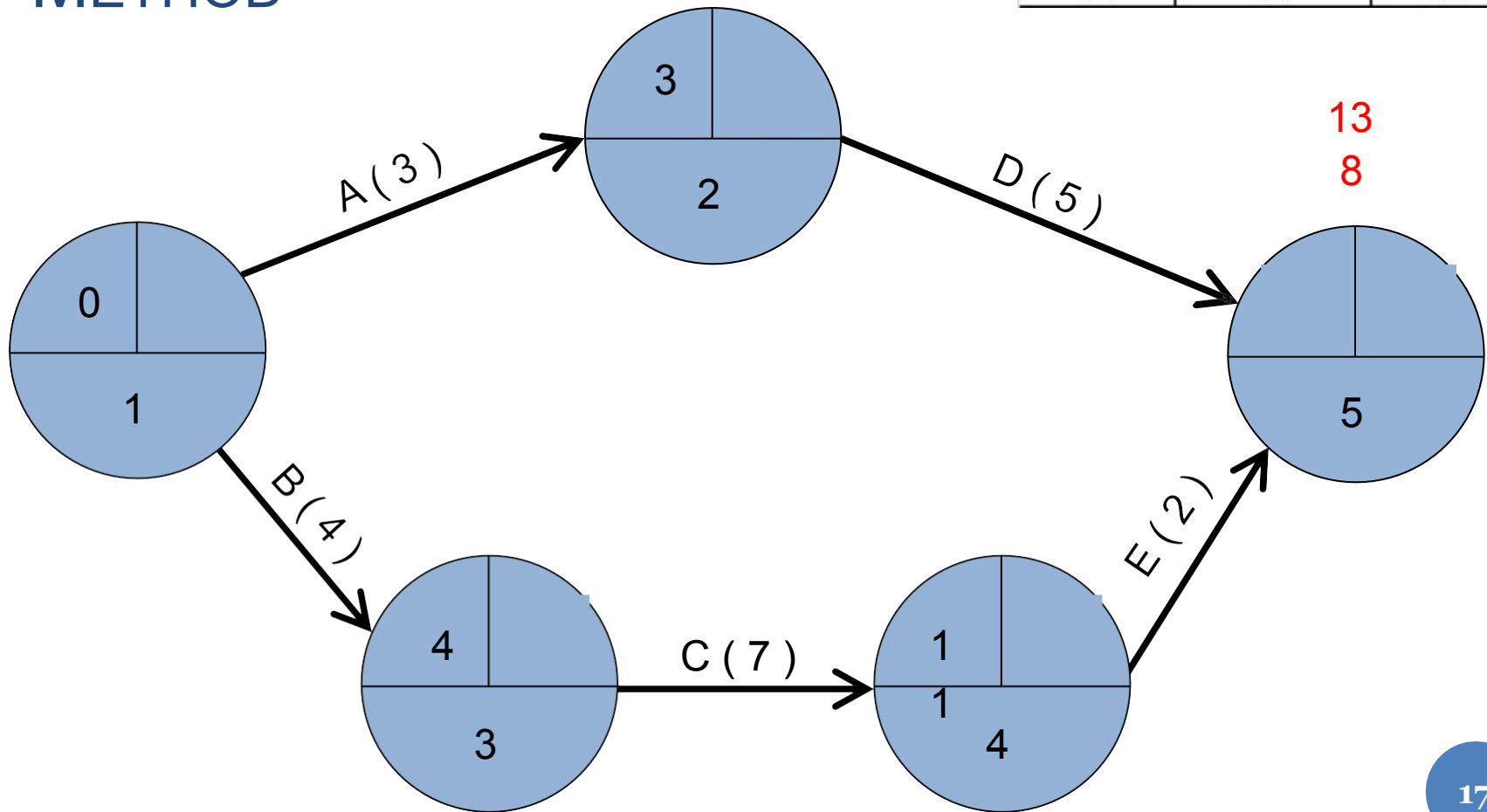

CPM – CRITICAL PATH METHOD

Task	Precedence	Duration
A	-	3
B	-	4
C	B	7
D	A	5
E	C	2

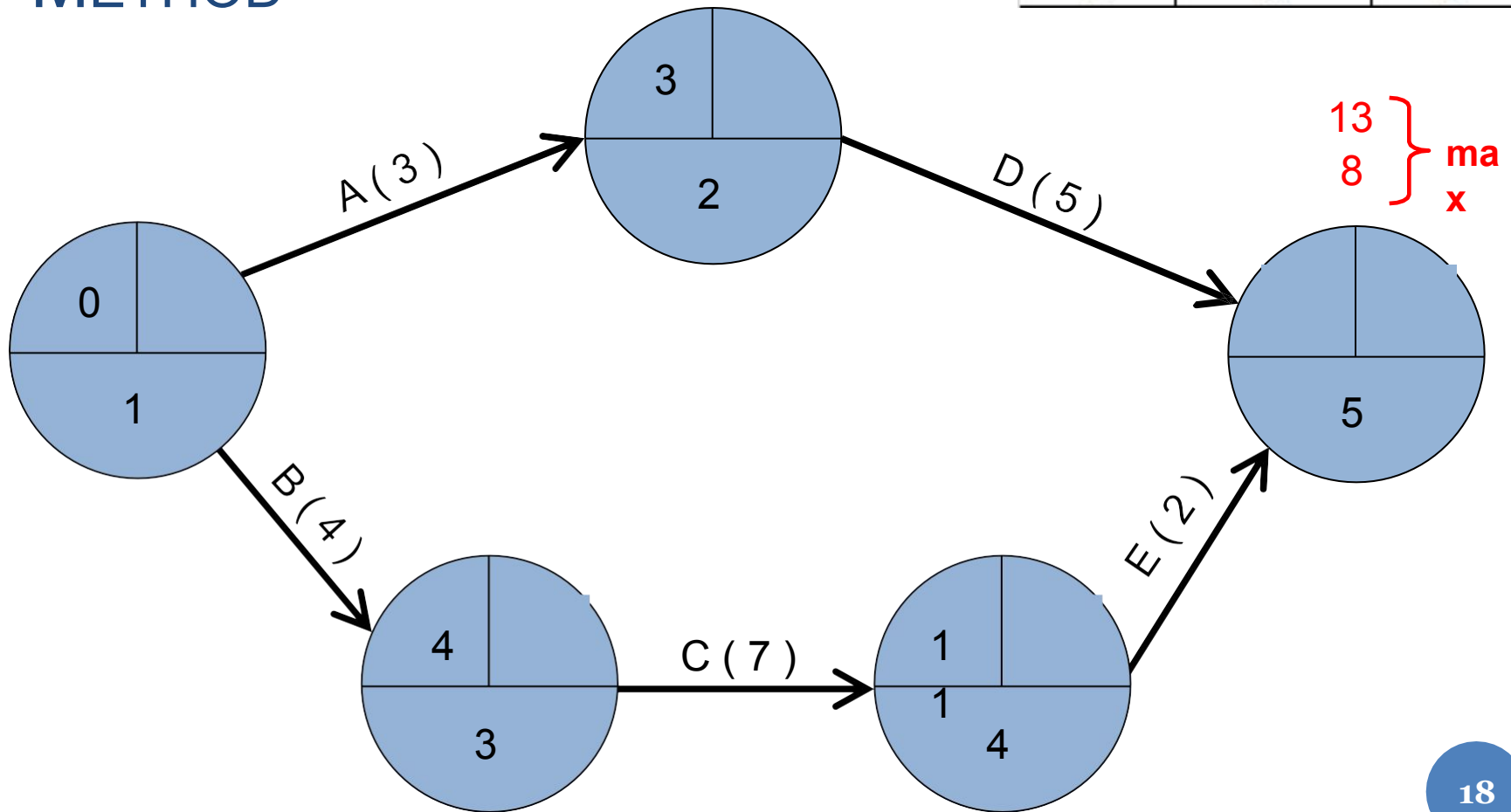

CPM – CRITICAL PATH METHOD

Task	Precedence	Duration
A	-	3
B	-	4
C	B	7
D	A	5
E	C	2

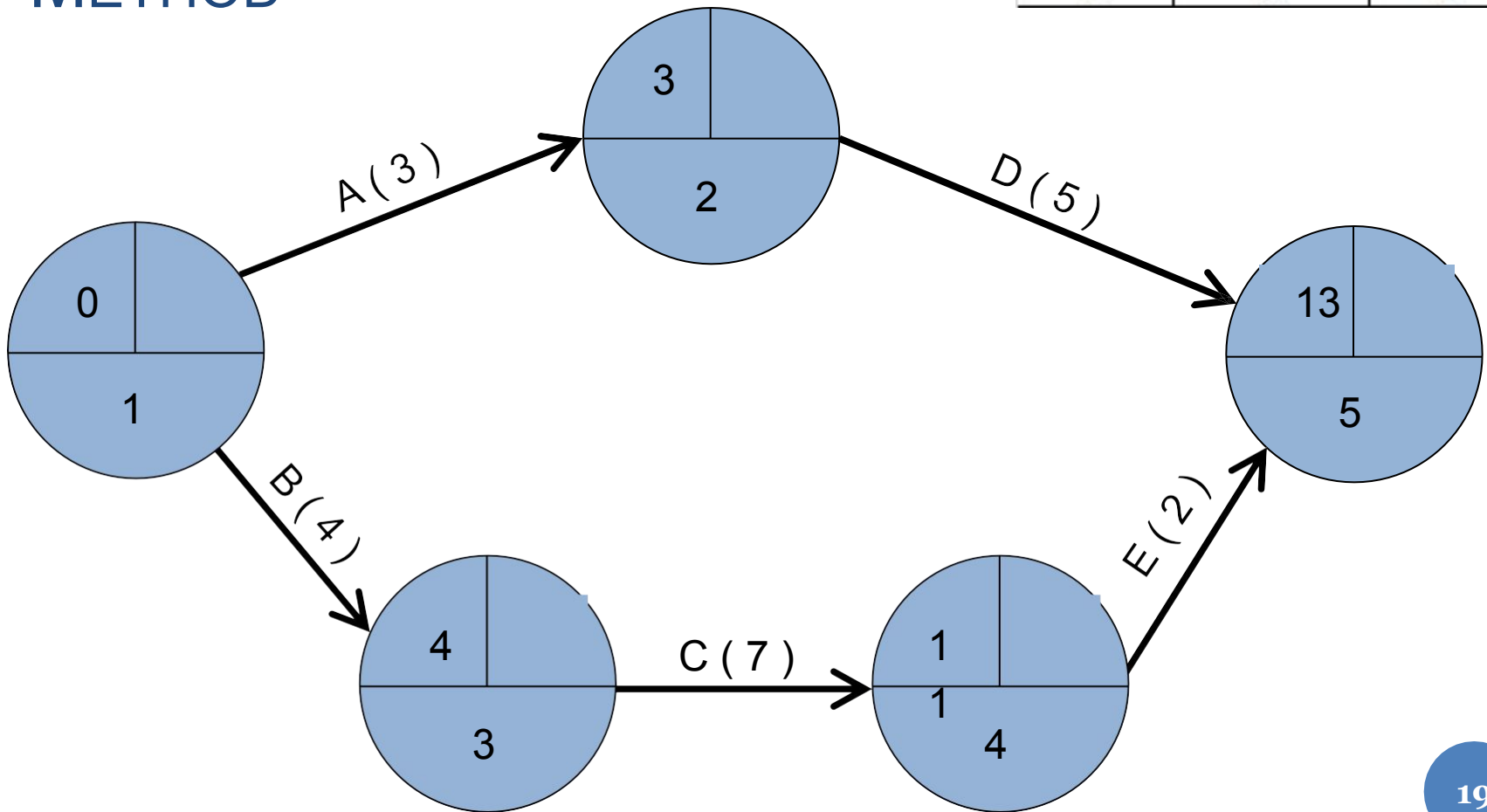

CPM – CRITICAL PATH METHOD

Task	Precedence	Duration
A	-	3
B	-	4
C	B	7
D	A	5
E	C	2

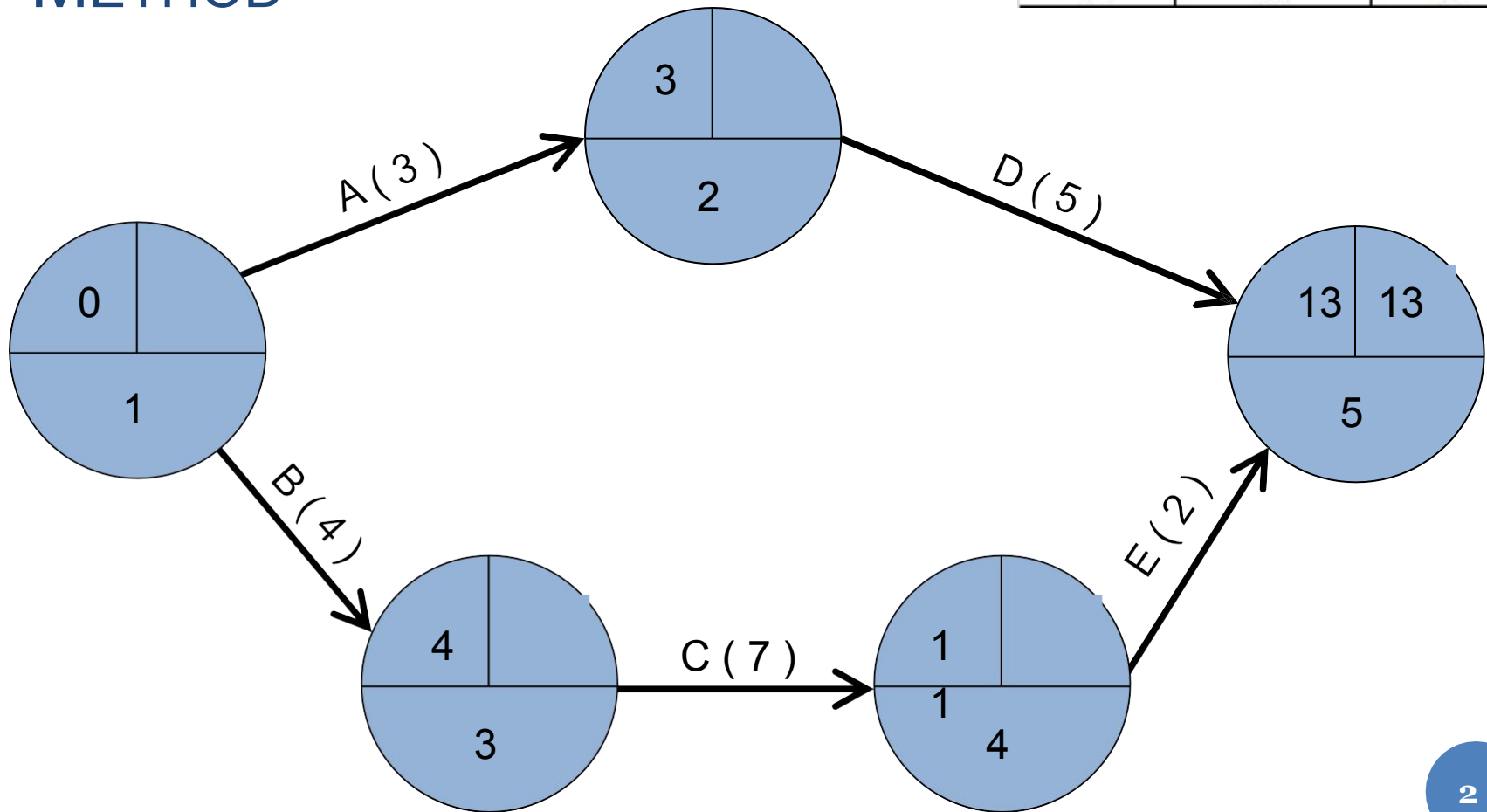

CPM – CRITICAL PATH METHOD

Task	Precedence	Duration
A	-	3
B	-	4
C	B	7
D	A	5
E	C	2

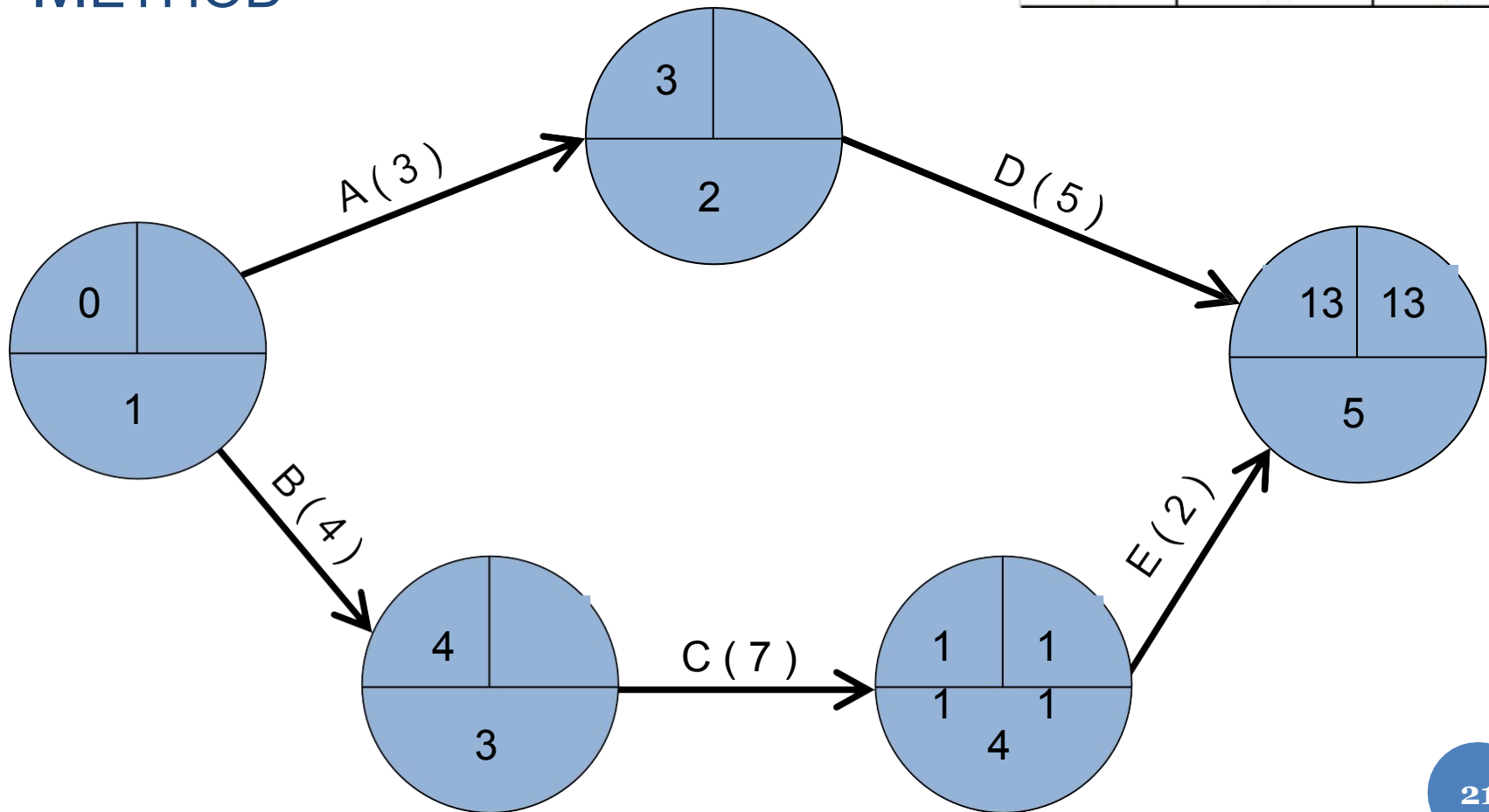

CPM – CRITICAL PATH METHOD

Task	Precedence	Duration
A	-	3
B	-	4
C	B	7
D	A	5
E	C	2

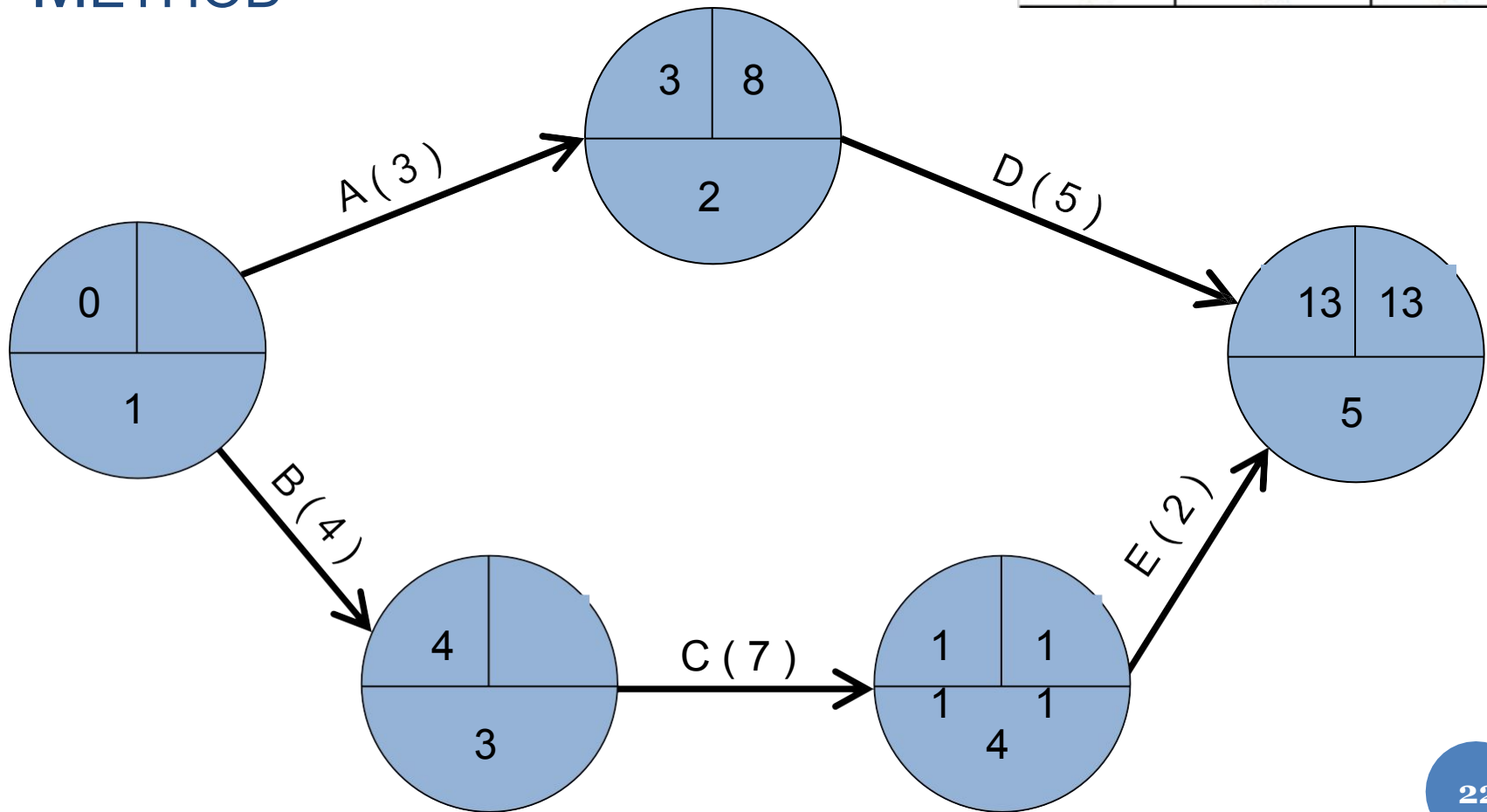

CPM – CRITICAL PATH METHOD

Task	Precedence	Duration
A	-	3
B	-	4
C	B	7
D	A	5
E	C	2

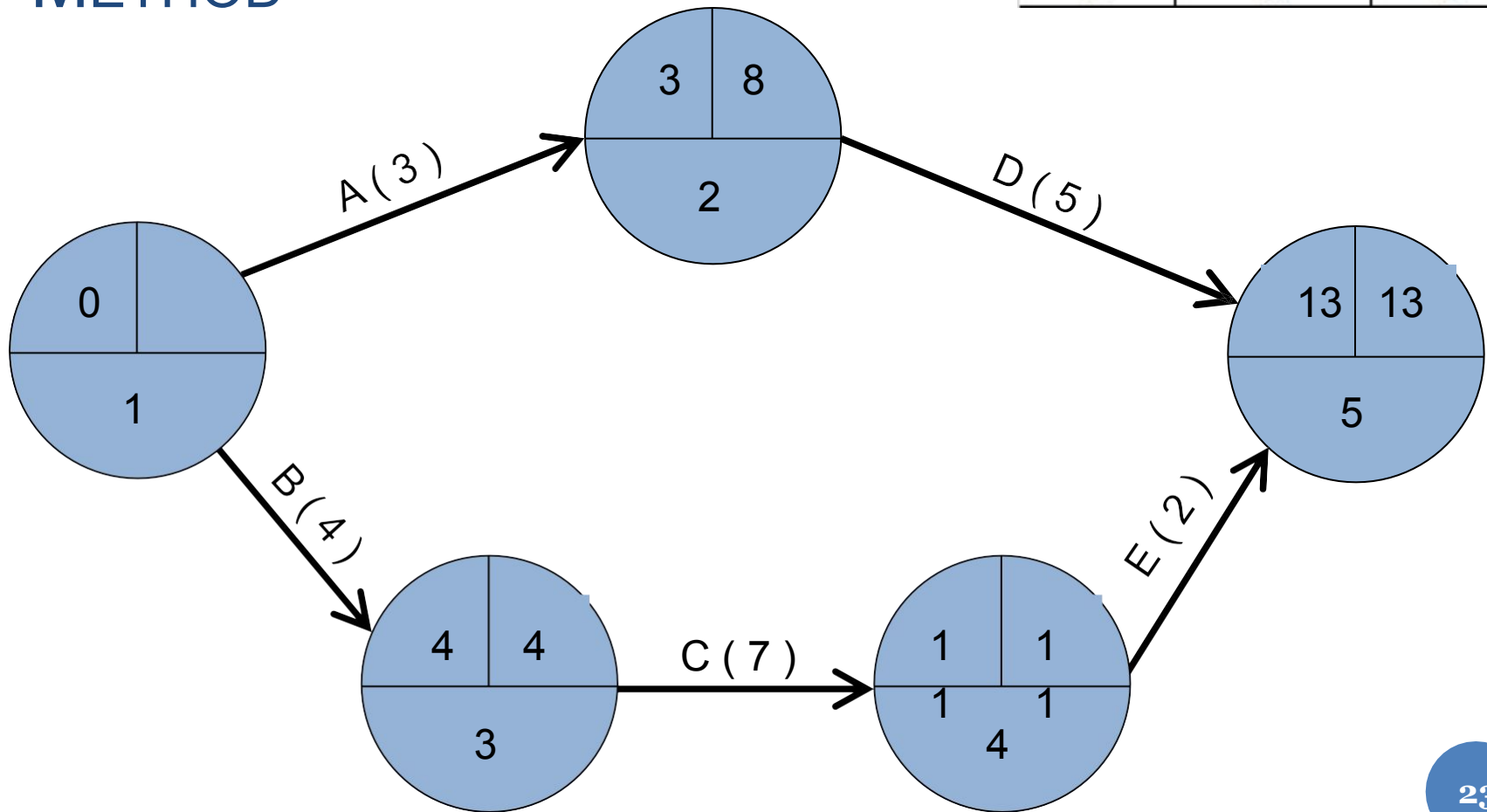

CPM – CRITICAL PATH METHOD

Task	Precedence	Duration
A	-	3
B	-	4
C	B	7
D	A	5
E	C	2

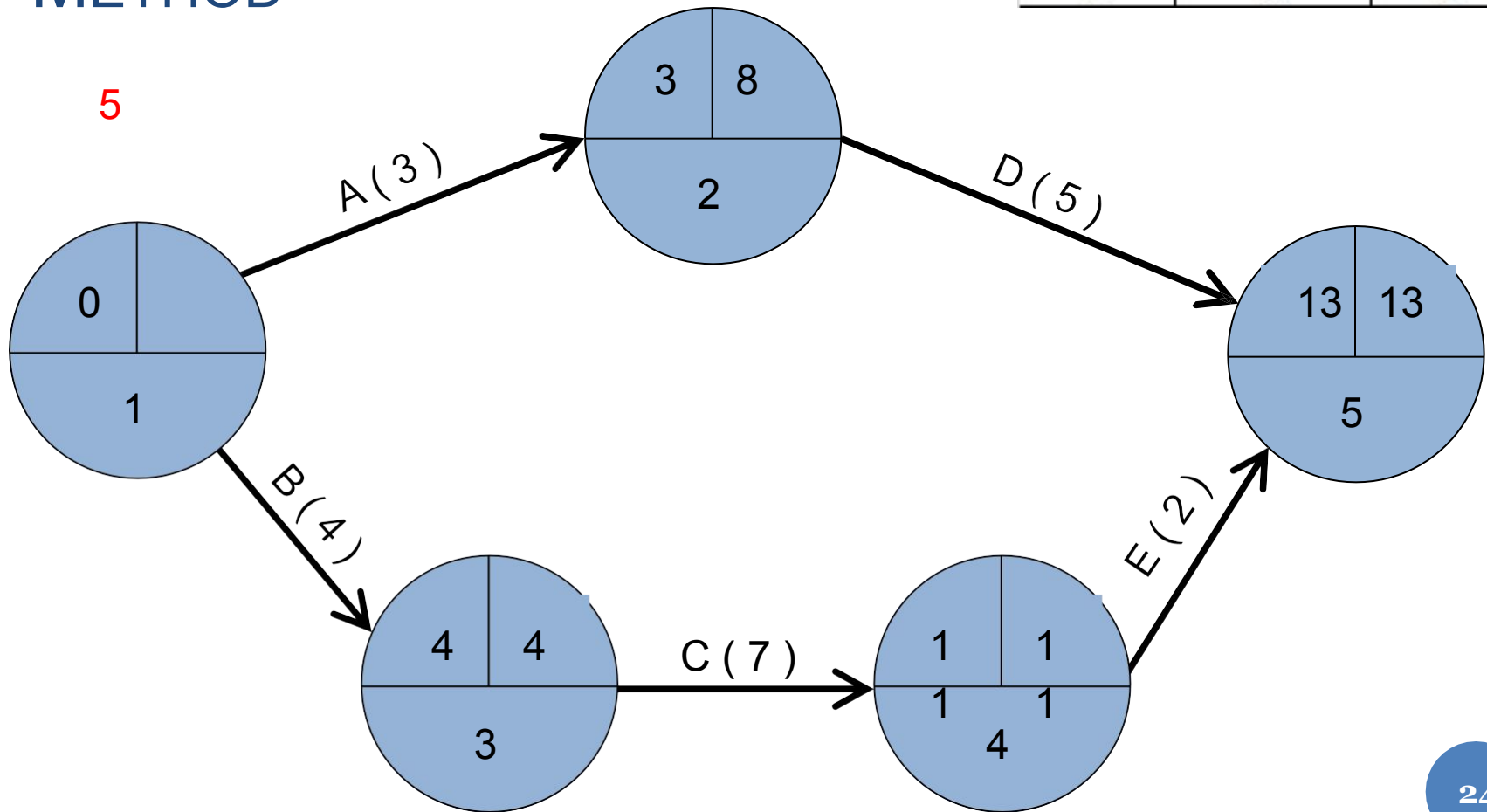

CPM – CRITICAL PATH METHOD

Task	Precedence	Duration
A	-	3
B	-	4
C	B	7
D	A	5
E	C	2

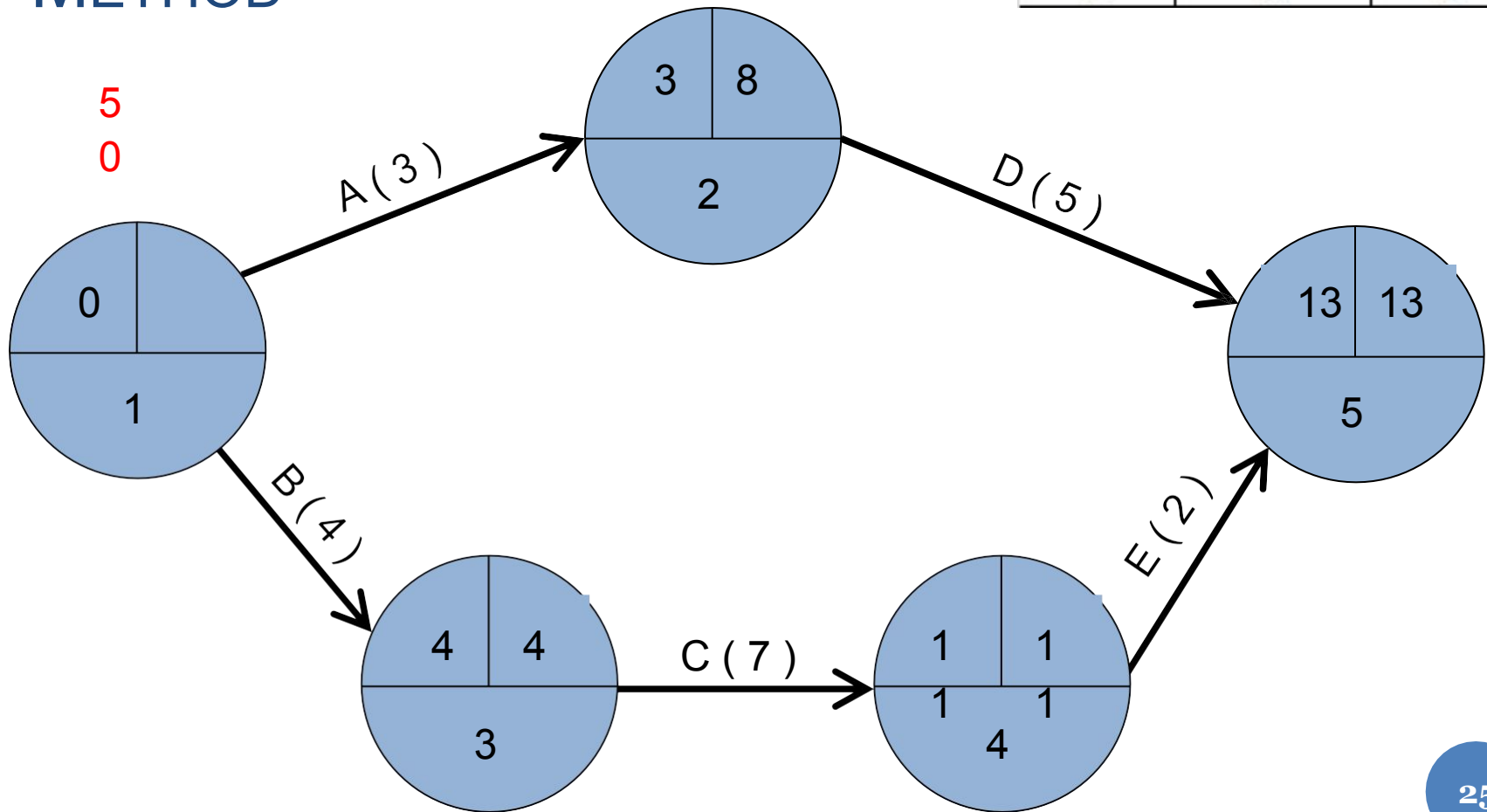

CPM – CRITICAL PATH METHOD

Task	Precedence	Duration
A	-	3
B	-	4
C	B	7
D	A	5
E	C	2

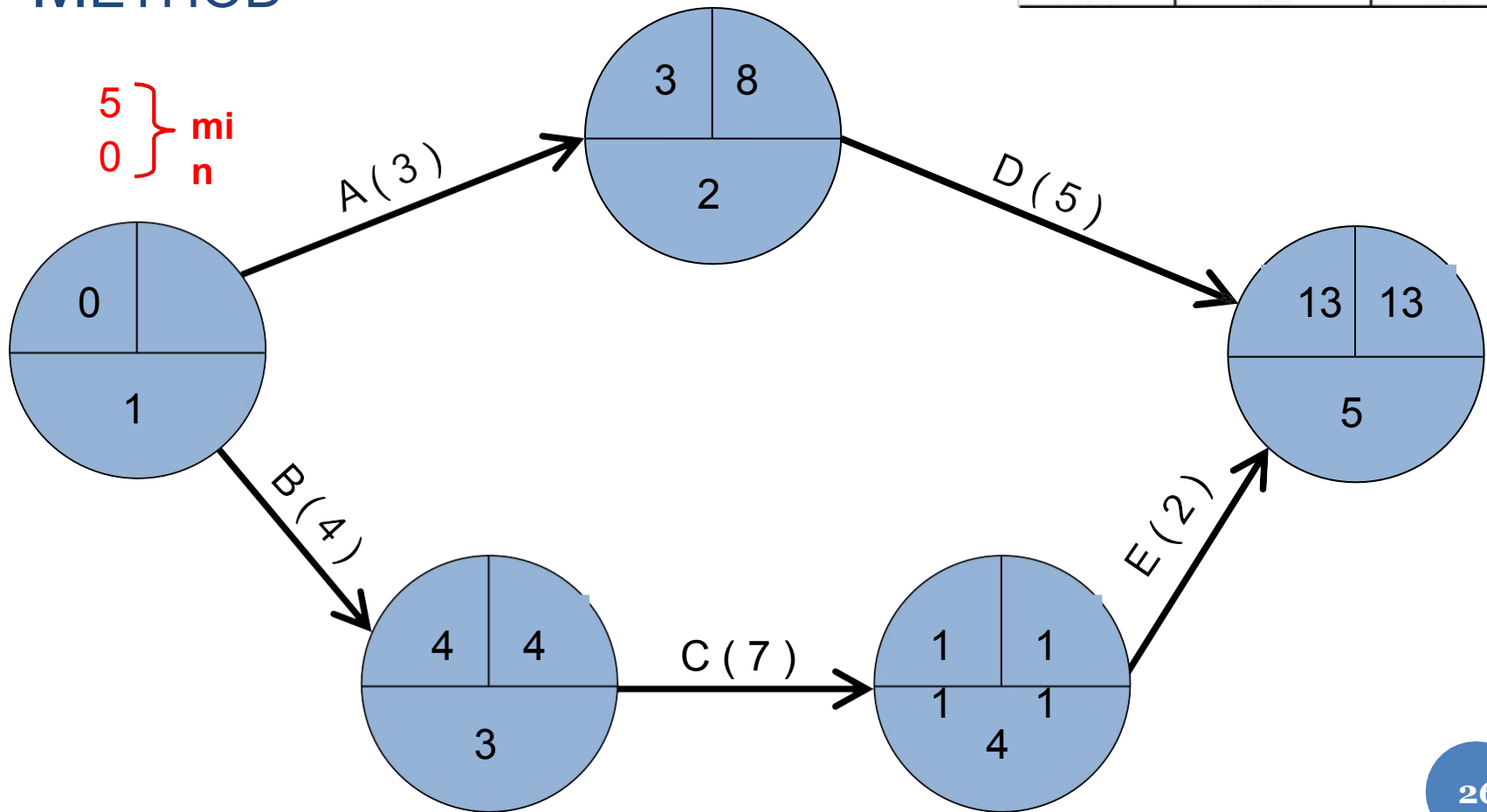

CPM – CRITICAL PATH METHOD

Task	Precedence	Duration
A	-	3
B	-	4
C	B	7
D	A	5
E	C	2

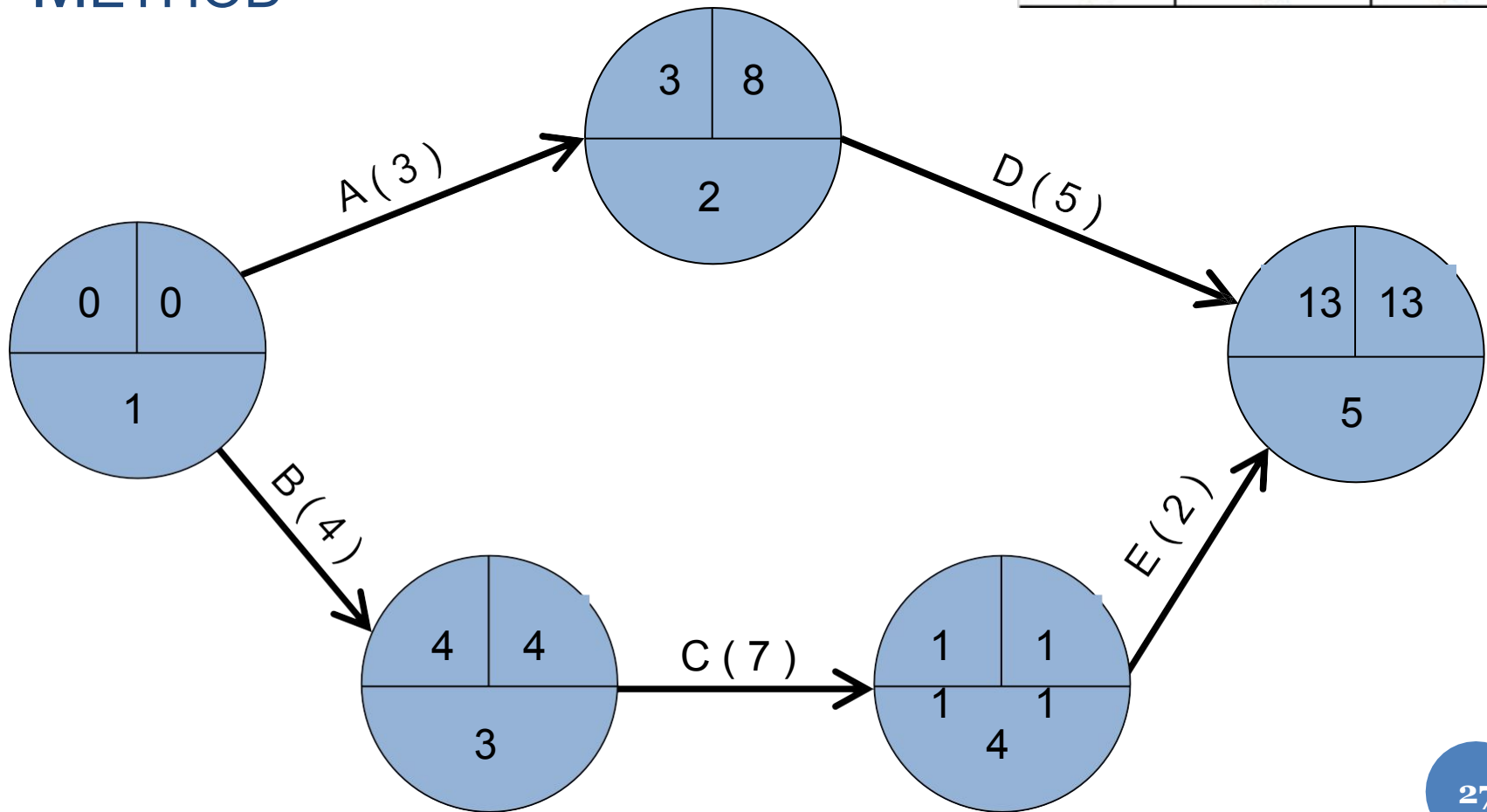

CPM – CRITICAL PATH METHOD

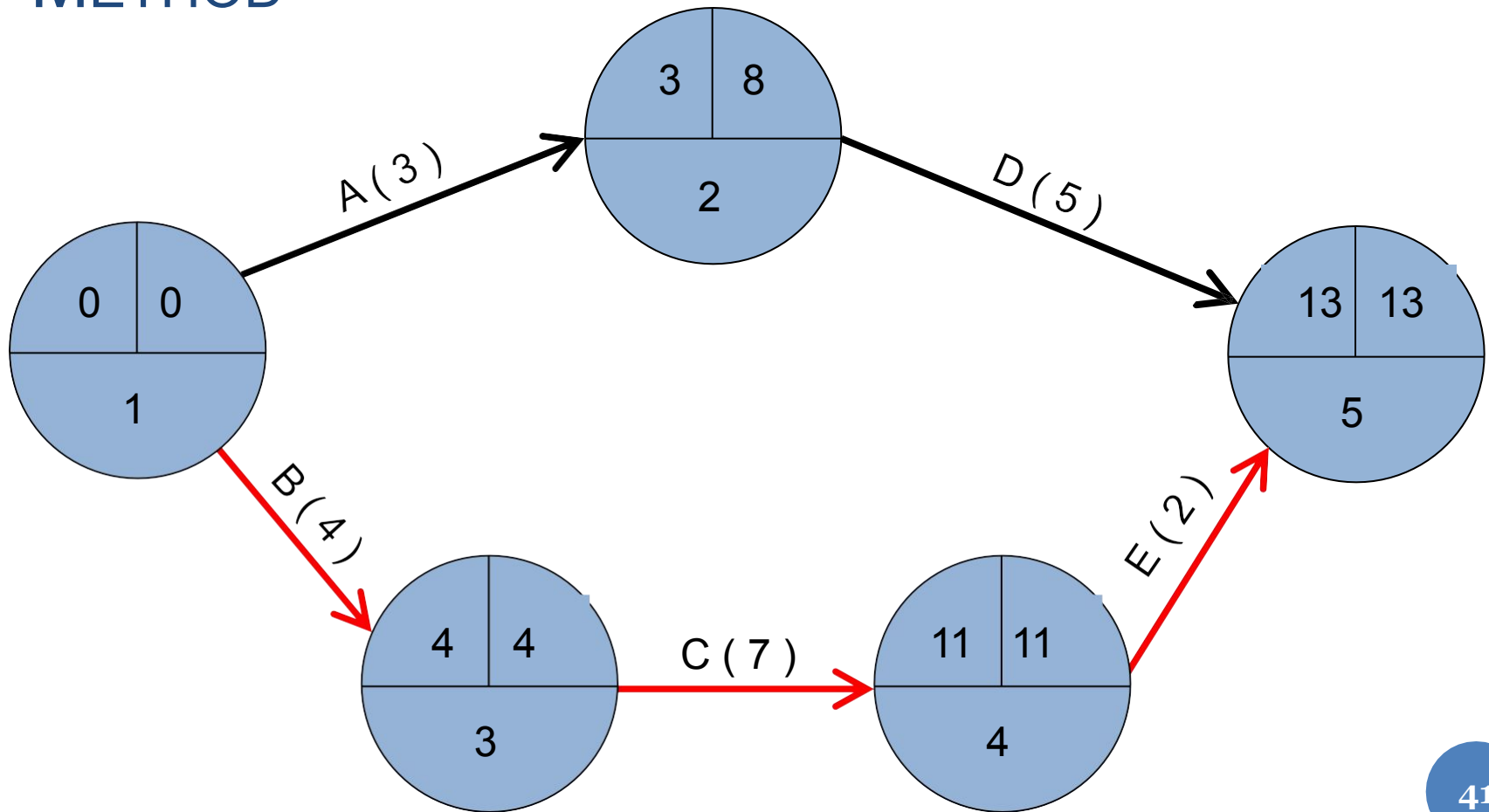

CPM – CRITICAL PATH

METHOD

- An activity with zero slack time is a **critical activity** and *cannot be delayed* without causing a delay in the whole project.

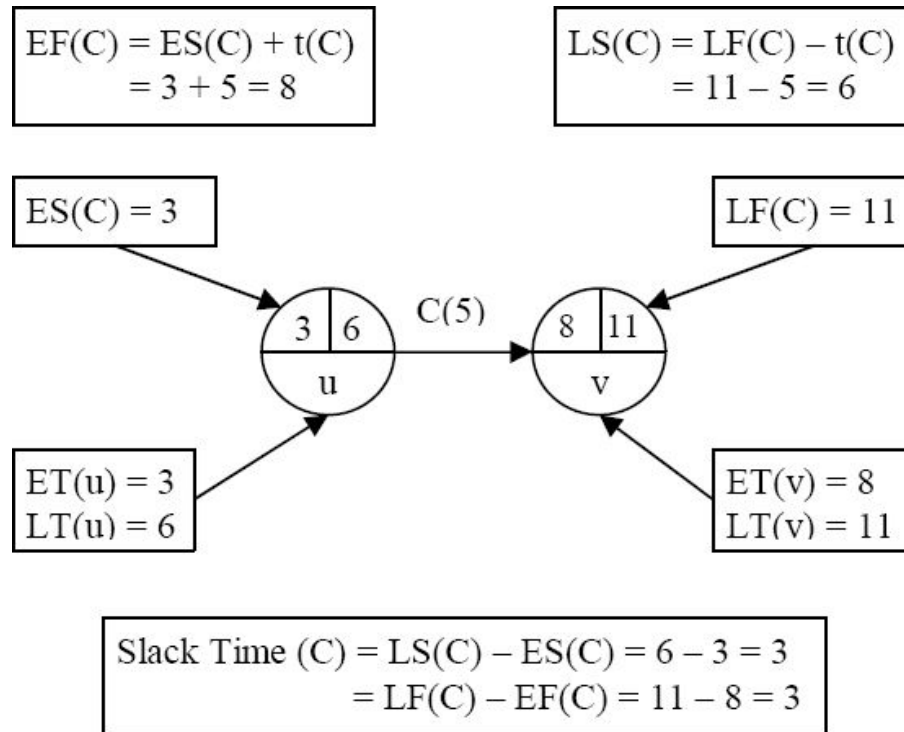

CPM – CRITICAL PATH METHOD

METHOD

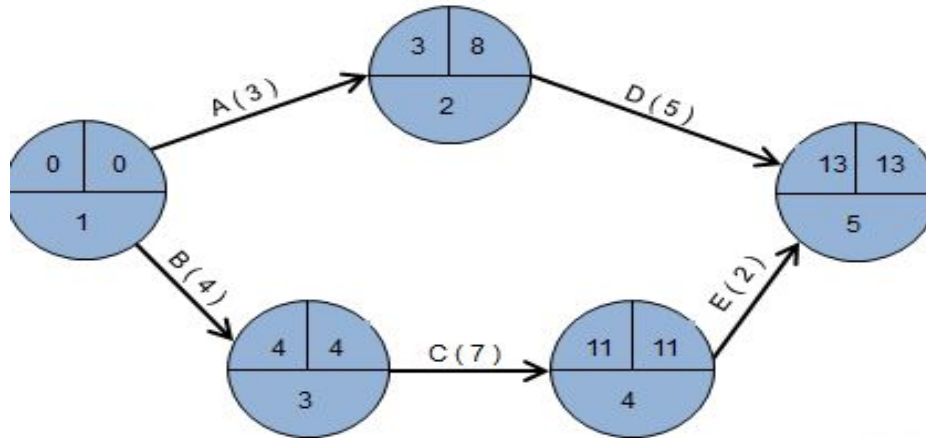

Step 3. Calculate processing times for each activity.

Task	Duration	ES	EF	LS	LF	Slack	Critical Task
A	3	0	3	5	8	5	No
B	4	0	4	0	4	0	Yes
C	7	4	11	4	11	0	Yes
D	5	3	8	8	13	5	No
E	2	11	13	11	13	0	Yes



LECTURE – GANTT CHART

- **GANTT Charts**
- **Constructing GANTT Charts**
- **Staffing**

GANTT

CHART

- A GANTT chart is a type of **bar chart** that illustrates a project schedule.
- After the PERT/CPM analysis is completed, the following phase is to construct the GANTT chart and then to re-allocate resources and re-schedule if necessary.
- GANTT charts have become a common technique for representing the phases and activities of a project **work breakdown structure**.
- It was introduced by Henry Gantt around 1910 – 1915.

GANTT CHART

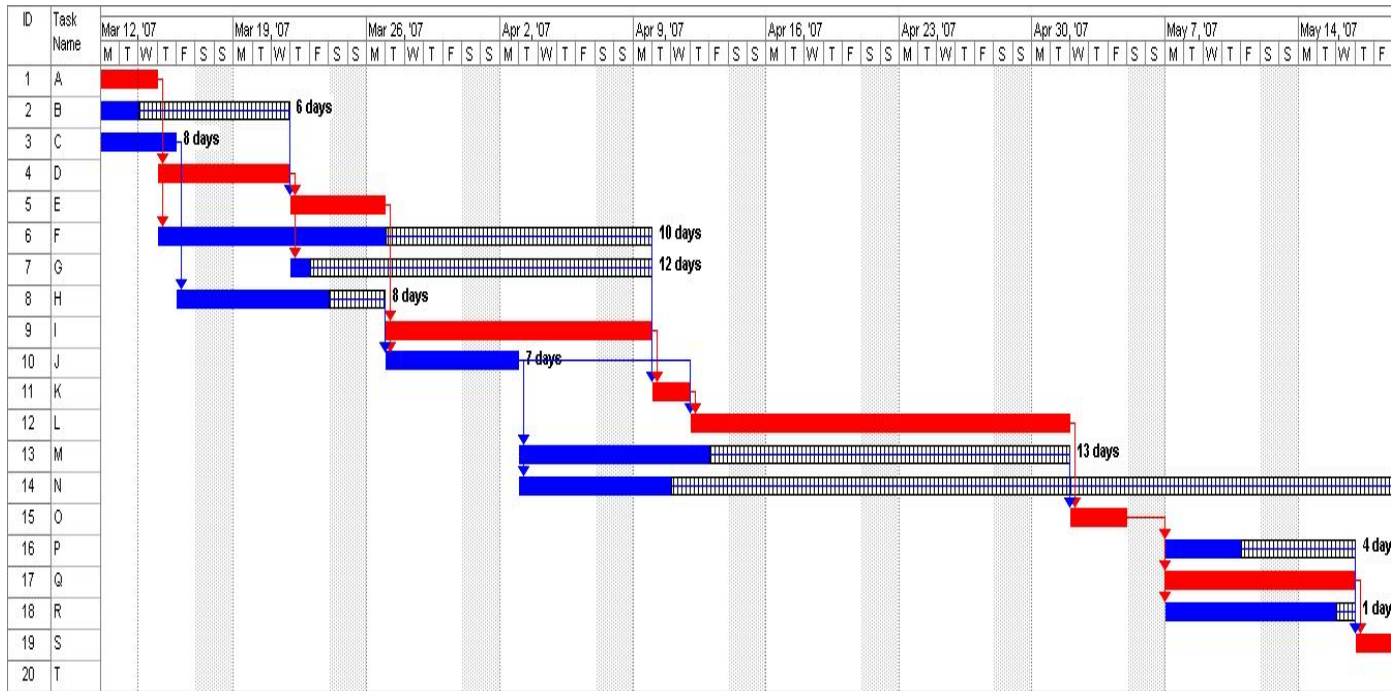

GANTT

CHART

□ Characteristic

- S: The bar in each row identifies the corresponding task
 - The horizontal position of the bar identifies start and end times of the task
 - Bar length represents the duration of the task
 - Task durations can be compared easily
 - Good for allocating resources and re-scheduling
 - Precedence relationships can be represented using arrows
 - Critical activities are usually highlighted
 - Slack times are represented using bars with dotted lines
 - The bar of each activity begins at the activity earliest start time (ES).
The bar of each activity ends at the activity latest finish time (LF).

GANTT

CHART

□ Advantages

- Simple
- Good visual communication to others
- Task durations can be compared easily
- Good for scheduling resources

□ Disadvantages

- Dependencies are more difficult to visualise
- Minor changes in data can cause major changes in the chart

CONSTRUCTING GANTT

CHART

- The steps to construct a GANTT chart from the information obtained by PERT CHART and CPM are:
 1. Schedule the critical tasks in the correct position.
 2. Place the time windows in which the non-critical tasks can be scheduled.
 3. Schedule the non-critical tasks according to their earliest starting times.
 4. Indicate precedence relationships between tasks.

CONSTRUCTING GANTT

CHART

- Example of an early GANTT chart construction:

Task	Duration	Precedence	ES	EF	LS	LF	Slack Time	Critical Task
A	3		0	3	3	6	3	N
B	4		0	4	0	4	0	Y
C	5	A	3	8	6	11	3	N
D	7	B	4	11	4	11	0	Y
E	2	B	4	6	8	10	4	N
F	4	E	6	10	10	14	4	N
G	3	C,D	11	14	11	14	0	Y

CONSTRUCTING GANTT

CHART

Step 1. Schedule critical
tasks

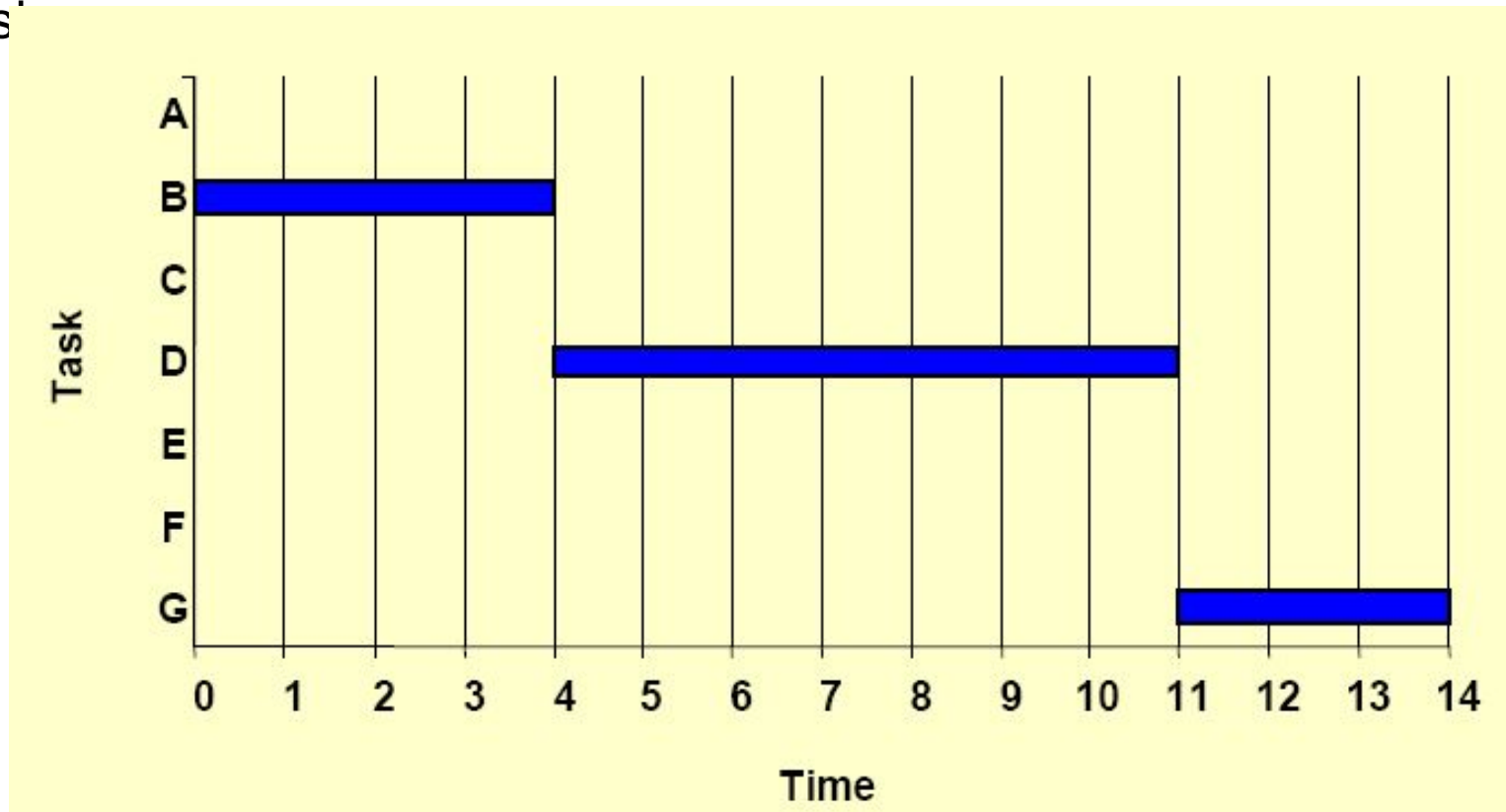

CONSTRUCTING GANTT

CHART

Step 2. Place time windows for non-critical tasks:

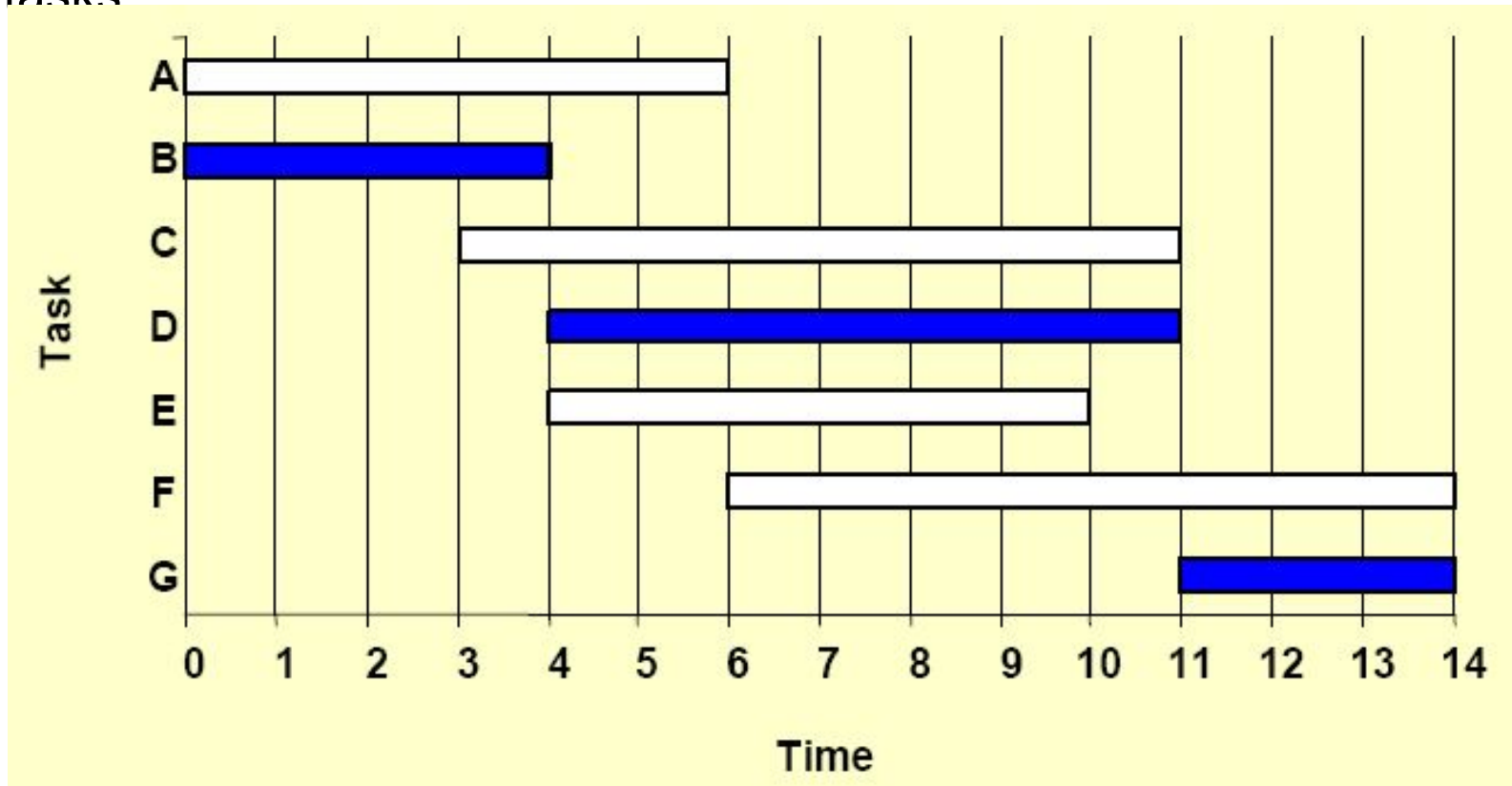

CONSTRUCTING GANTT

CHART

Step 3. Schedule non-critical tasks

Step 4. Indicate precedence

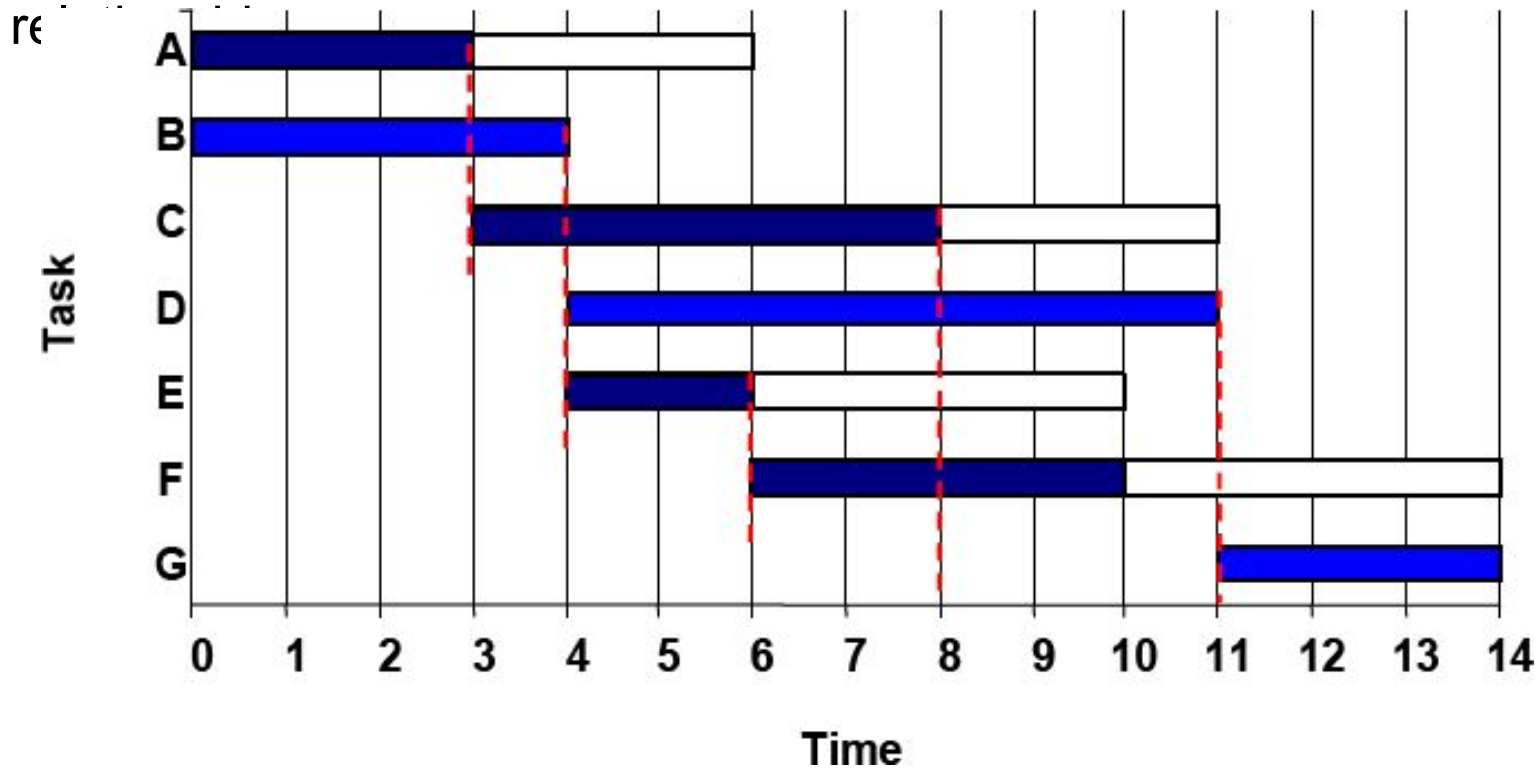

STAFFING

- **Staff Utilization:** *(duration of activity x staff required for each activity, all added together) / (maximum staff required x duration of project)*

STAFFING

The original schedule (constructed above) for this project is as shown below.

Task	Duration	Staff Needed
A	3	2
B	4	4
C	5	1
D	7	3
E	2	1
F	4	2
G	3	5

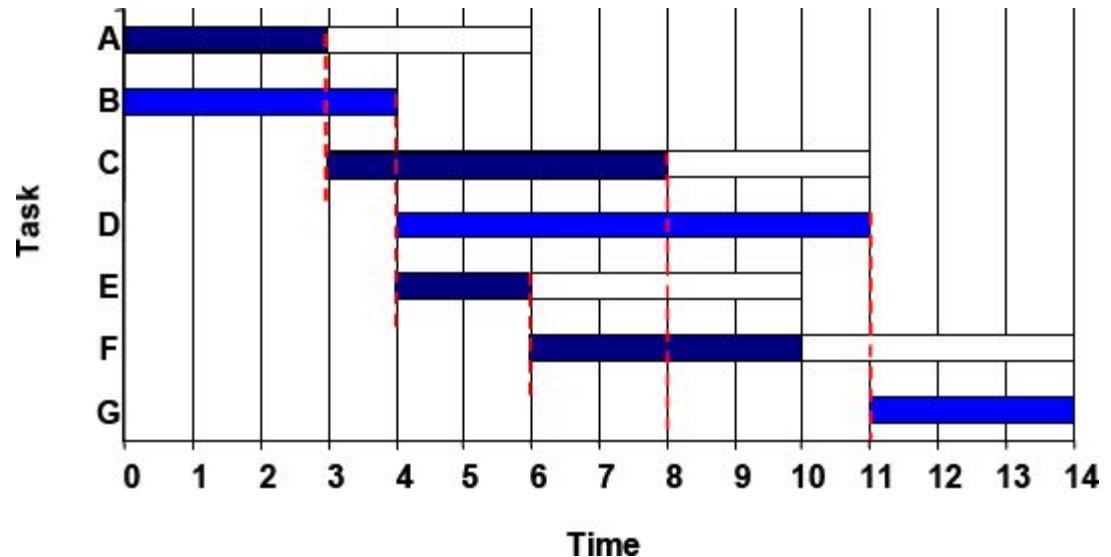

1. Staff utilisation = $(3 \times 2 + 4 \times 4 + 5 \times 1 + 7 \times 3 + 2 \times 1 + 4 \times 2 + 3 \times 5) / (14 \times 6) = 0.857$
= 85.5%